



## Research Article

# Theoretical and practical analysis of parallel operating conditions of two transformers with different relative short circuit voltages

Burak Bugra KUCUKKAYA<sup>1,\*</sup> , Nihat PAMUK<sup>1</sup> 

<sup>1</sup>Department of Electrical Electronics, Zonguldak Bulent Ecevit University, Zonguldak, 67100, Türkiye

## ARTICLE INFO

### Article history

Received: 23 September 2022

Revised: 04 December 2022

Accepted: 16 January 2023

### Keywords:

Different Short-Circuit Voltage,  
Distribution Transformers,  
Parallel Operation in  
Transformers, Vector Groups,  
Safety Margin

## ABSTRACT

The safety of the electrical energy supply is one of the most critical issues for companies engaged in production. The internal distribution network, which will provide the energy for the production elements, is essential. Power Transformers, which energize the loads fed from the electricity distribution network, are backed up in a way suitable for parallel operation for energy supply security. As a result of this situation, in case of a predictive failure in one of the transformers, energy supply safety is ensured since the other transformer is designed to carry the load alone. When one of these identical transformers is damaged, the relative short-circuit voltage of the new transformer to be integrated into the system may be different. The transformers with different short-circuit voltages are not shared their load equally. For this reason, the total amount of load that they can be loaded, the relative short-circuit voltage that will occur, and the load rates they are loaded change. In this study, a detailed analysis of two transformers with different relative short-circuit voltages and operating in parallel was made, both theoretically and as a result of the application, with the information obtained through the SCADA program. The theoretical values were calculated as a result of the analysis, the SCADA values were compared, and the margin of safety between them was established. It has been shown that the safety margin will protect against overload on a low short-circuit transformer. After the commissioning, the load rating needs to check and it can be regulated in line with the load rates that will occur after commissioning.

**Cite this article as:** Kucukkaya BB, Pamuk N. Theoretical and practical analysis of parallel operating conditions of two transformers with different relative short circuit voltages. Sigma J Eng Nat Sci 2024;42(3):701–713.

## INTRODUCTION

Transformers are operated in parallel in power plants and transformer centers. When the power of an existing transformer substation cannot meet the load in the face of ever-increasing consumption, it is more economical to

operate the transformers in parallel, which will be added in line with the load increase, instead of replacing the transformers [9]. When operating the system with two or more transformers instead of using a single transformer, in case of a failure in one transformer, the system can be continued

### \*Corresponding author.

\*E-mail address: burakbugrakucukkaya@gmail.com

This paper was recommended for publication in revised form by  
Regional Editor Osman Nuri Uçan



by being loaded at the rate of the other transformer's power. Since the backup transformer power needed by the transformers operated in parallel will be reduced by half, the cost will decrease. When the load in the system decreases, one of the two transformers is deactivated, preventing low-efficiency operation at small loads.

Suppose an existing transformer in the system does not meet the demanded load. In that case, another transformer with the same technical specifications can operate parallel with the existing transformer to meet the demand. Transformers can take 5-6 months to produce, and 2-3 months to repair [1-19]. A transformer operating integrated into the system may be subject to a major failure. In this case, it is necessary to examine which of the existing spare transformers can work by connecting them in parallel. Spare transformer specifications can be different from the main transformer. In this situation, the parallel operation conditions must be checked [2].

Various conditions are required for the parallel connection of transformers with different specifications. Therefore, this study analyzed the parallel operation of two transformers with different short-circuit voltages, and the differences that occurred during the application were examined. In addition, this study includes the theoretical calculation and the safety margin before the load maximum to parallel-operated transformers with different short circuit voltage values. According to literature research, the parallel operation of the different relative short circuit voltage transformers was checked theoretically. In this study, the simulation calculates the parallel operation, and after the simulation, the operational results are analyzed by SCADA.

## PARALLEL OPERATING CONDITIONS IN TRANSFORMERS

The following conditions must be met to divide the total load between transformers operating in parallel to their rated power and prevent balancing currents between transformers in no-load operation [4–10–18]. Parallel operation conditions are listed as follows:

- Vector groups must be the same.
- No-load Voltage ratio must be equal.
- Relative short circuit voltages must be equal.
- Frequency must be equal.
- Nominal power ratio should not be less than 1/3 [3–11–14]

### No-Load Parallel Operation

Suppose two transformers operating in parallel operation have the same no-load voltage ratios. In that case, their no-load secondary voltages are equal, and no circulating current occurs between them. However, if the idling ratios differ, a circulating current calculated in Equation 1 will occur between the two transformers [23].

$$I = \frac{\Delta u}{U_{k1} + \left(\frac{S_{N1}}{S_{N2}}\right) \times U_{k2}} \times 100(\%) \quad (1)$$

In equation 1;

I = 1. The circulating current as a percentage of the rated current of the transformer,

$\Delta u$  = In no-load operation, the difference between the secondary voltages of both transformers is expressed as a percentage of the secondary voltage of the 1<sup>st</sup> transformer;

$U_{k1}, U_{k2}$  = Short circuit voltages of 1<sup>st</sup> and 2<sup>nd</sup> transformers

$S_{N1}, S_{N2}$  = Rated powers of 1<sup>st</sup> and 2<sup>nd</sup> transformer

$$\% \Delta u = \frac{(U_{01} - U_{02}) \times 100}{U_{01}} \quad (2)$$

If the powers are different, the tiny power transformer is used as the basis and with the index "1" [1 – 15]. The transformer with the higher idle voltage feeds the other. If conditions b and c are not met, the internal circulation currents cannot be prevented, and this internal circulation current causes the transformer windings to heat up and fail [13].

### Parallel Operation on Load

The sum of rated powers of "n" transformers operating in parallel is shown with " $S_N$ ".

$$S_N = S_{N1} + S_{N2} + \dots + S_{Nn} \quad (3)$$

The equivalent short-circuits voltage of "n" transformers with the same conversion ratios but different rated powers and short-circuit voltages is given in equation 4.

$$U_k = \frac{S_N}{\frac{S_{N1}}{U_{k1}} + \frac{S_{N2}}{U_{k2}} + \dots + \frac{S_{Nn}}{U_{kn}}} \quad (4)$$

Assuming that the connection groups and frequencies are the same, the parallel operating conditions consist of 3 parts[6]. These are the no-load voltage ratio, short-circuit voltage, and rated power. If one, two, or all three of the three conditions are different, how the total "S" load will be divided among the transformers in parallel operation is examined below [5 – 22].

a) The case where only the rated powers are different is given in equation 5:

$$S_1 = \frac{S}{S_N} \times S_{N1}, \quad S_2 = \frac{S}{S_N} \times S_{N2}, \quad S_n = \frac{S}{S_N} \times S_{Nn} \quad (5)$$

The transformer with the enormous rated power is loaded with a bigger load.

b) If only the short-circuit voltages are different, it is given in equation 6:

$$S_1 = \frac{S}{n} \times \frac{U_k}{U_{k1}}, \quad S_2 = \frac{S}{n} \times \frac{U_k}{U_{k2}}, \quad \dots \dots \dots \quad S_n = \frac{S}{n} \times \frac{U_k}{U_{kn}} \quad (6)$$

c) The case where both short-circuit voltages and rated powers are different is given in equation 7:

$$S_1 = S \times \frac{S_{N2}}{S_N} \times \frac{U_k}{U_{k2}}, S_1 = S \times \frac{S_{N2}}{S_N} \times \frac{U_k}{U_{k2}}, \dots, S_n = S \times \frac{S_{Nn}}{S_N} \times \frac{U_k}{U_{kn}} \quad (7)$$

d) The case where both the no-load voltage ratios, short-circuit voltages, and rated powers are different is given in equations 8,9, and 10:

$$S_1 = \left( \frac{S}{100} + \frac{S_{N2}}{U_{k2}} \times \frac{U_{o1} - U_{o2}}{U_{o2}} + \frac{S_{N3}}{U_{k3}} \times \frac{U_{o1} - U_{o3}}{U_{o3}} + \dots + \frac{S_{Nn}}{U_{kn}} \times \frac{U_{o1} - U_{on}}{U_{on}} \right) \times \frac{100 \times S_{N1} \times U_k}{S_N \times U_{k1}} \quad (8)$$

$$S_2 = \left( \frac{S}{100} + \frac{S_{N1}}{U_{k1}} \times \frac{U_{o2} - U_{o1}}{U_{o1}} + \frac{S_{N3}}{U_{k3}} \times \frac{U_{o2} - U_{o3}}{U_{o3}} + \dots + \frac{S_{Nn}}{U_{kn}} \times \frac{U_{o2} - U_{on}}{U_{on}} \right) \times \frac{100 \times S_{N2} \times U_k}{S_N \times U_{k2}} \quad (9)$$

$$S_n = \left( \frac{S}{100} + \frac{S_{N1}}{U_{k1}} \times \frac{U_{on} - U_{o1}}{U_{o1}} + \frac{S_{N2}}{U_{k2}} \times \frac{U_{on} - U_{o2}}{U_{o2}} + \dots + \frac{S_{N(n-1)}}{U_{k(n-1)}} \times \frac{U_{on} - U_{o(n-1)}}{U_{o(n-1)}} \right) \times \frac{100 \times S_{Nn} \times U_k}{S_N \times U_{kn}} \quad (10)$$

Given in Equations 7, 8, and 9;

$U_{01}, U_{02}, \dots, U_{0n}$  is defined as the no-load secondary voltages of the transformers.

$S_1, S_2, S_n$  the first terms define the power drawn from the network, and the other terms define the circulation or balancing powers between the transformers.

They can be in (+) or (-) polarity. But ultimately, their sum is zero. The sign of  $S_D$  balancing power is (-) polarity in a transformer with high secondary voltage [16].

If conditions d and e are not met, the transformer with a low percent short-circuits voltage as a result of unbalanced loading of the transformers will create a danger after the transformer is loaded more than the rated power of the transformer [17].

## PARALLEL OPERATION

### Power Distribution

For transformers connected in parallel, the load distribution, the current drawn by each transformer, or the apparent power it receives must be known. These data enable us to take measures to prevent overloads and to examine the power distributions that will occur on transformers.

a) In case all the features of the transformer connected in parallel are equal, the calculations to be made are defined in Equation 10 and Equation 11;

$$I = I_1 + I_2 \quad (11)$$

$$S = S_1 + S_2 \quad (12)$$

Given in Equation 10 and Equation 11, “I” represents the current drawn by the system (A), “S” the power of the system (kVA), “ $I_1$ ” the current of the first transformer (A), “ $I_2$ ” the current of the second transformer (A), “ $S_1$ ” the current of the first transformer, the power of the transformer (kVA), “ $S_2$ ” defines the power of the second transformer (kVA). The power of the system is shared equally by the two transformers.

b) In case the short circuit voltages of the transformers connected in parallel are not equal, the calculations to be made are defined in Equation 12, Equation 13, Equation 14, and Equation 15;

$$S_{total} = S_1 + S_2 + S_3 \quad (13)$$

$$U_{k(new)} = \frac{S_{total}}{\frac{S_1}{U_{k1}} + \frac{S_2}{U_{k2}} + \frac{S_3}{U_{k3}}} \quad (14)$$

$$S_{n(load)} = S_{load} \times \left( \frac{U_{k(new)}}{U_{kn}} \times \frac{S_n}{S_{total}} \right) \quad (15)$$

$$S_{max} = \left( \frac{U_{k(min)}}{U_{k1}} \times S_1 \right) + \left( \frac{U_{k(min)}}{U_{k2}} \times S_2 \right) + \left( \frac{U_{k(min)}}{U_{k3}} \times S_3 \right) \quad (16)$$

It defines the new short-circuit voltage (%) that will occur during the parallel operation of transformers that will operate in parallel with the  $U_{k(new)}$ .  $S_{n(load)}$  (kVA) defines the load to be loaded by the transformers that will operate in parallel during parallel operation.  $S_{max}$  (kVA) defines the maximum load. We can load the transformers that will operate in parallel [11].  $S_1, S_2,$  and  $S_3$  (kVA) define the nominal power of transformers.  $U_{k1}, U_{k2}, U_{k3}$  (%) It defines the short circuit voltage of transformers. Stop (kVA) defines the sum of the rated power of transformers.

**Table 1.** Main Transformers Technical Information

Transformers Technical Informationx	TR1 Technical Informations	TR2 Technical Informations
Transformer Power Rate (kVA):	6000	6000
Serial Number:	TN:239	TN: 240
Short-Circuit Impedance (%):	6,41	6,41
Vector Group:	Dyn11	Dyn11
Primary Voltage (kV):	13,8	13,8
Secondary Voltage (kV):	2,4	2,4
Frequency (Hz):	50	50

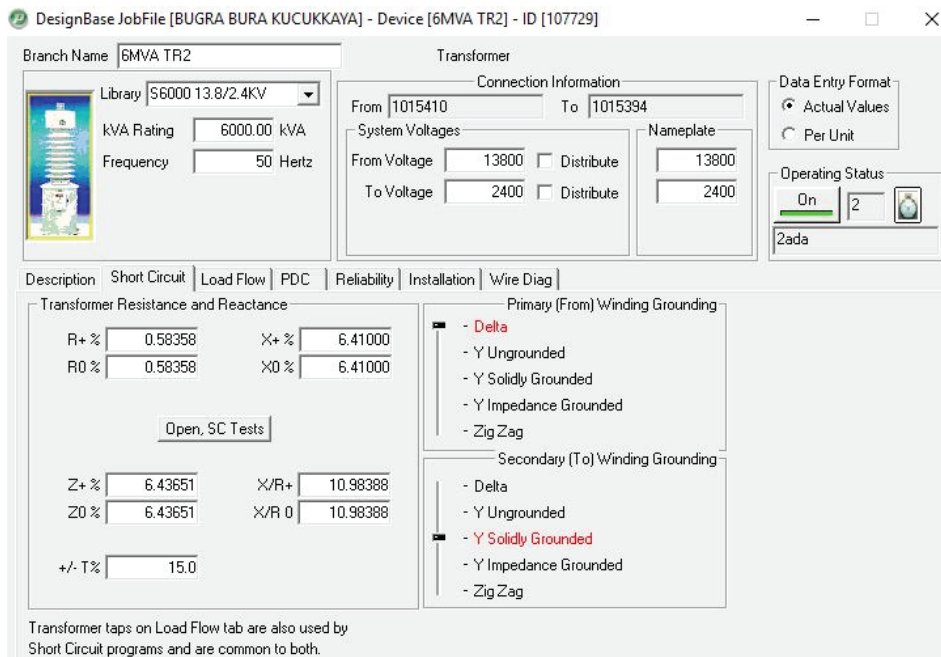

Figure 1. TR1-TR2 Transformer Technical Specification in Simulation Program.

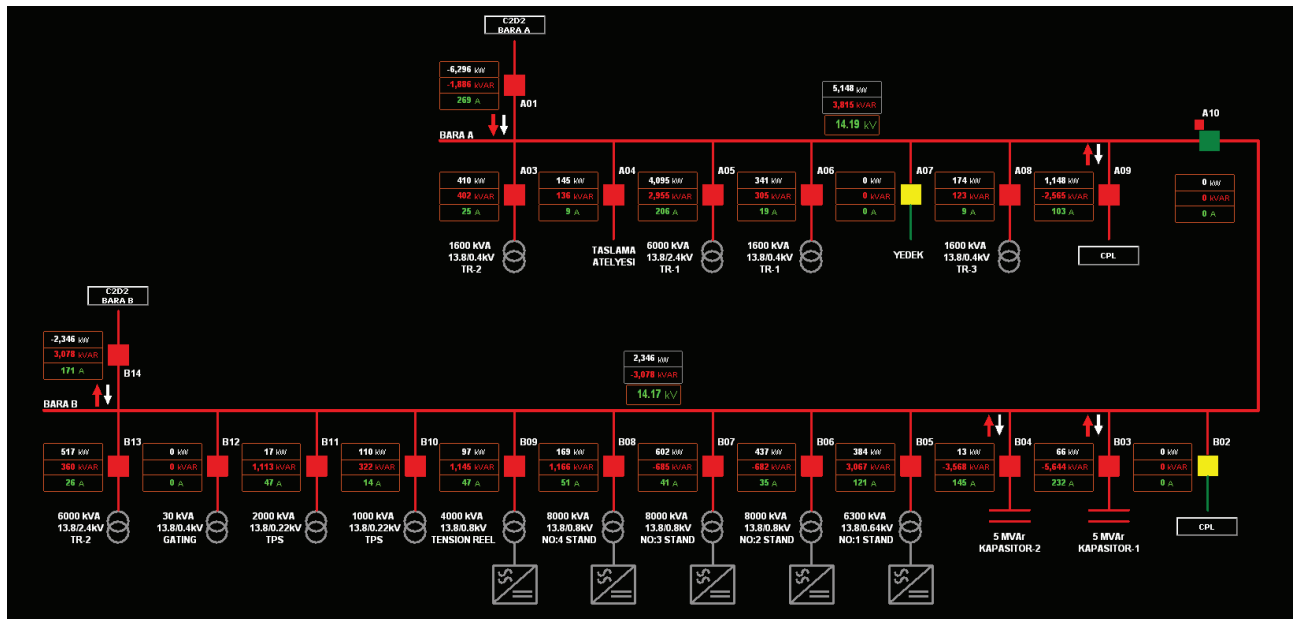

Figure 2. TCM Transformer center in Siemens Scada.

### Investigation of Parallel Operation of Two Transformers with Equivalent Technical Specifications

The technical specifications of the two transformers with equivalent technical specifications operating at the ERDEMIR TCM Transformer Center are indicated in Table 1. The First and Second transformers are the transformers operating in the current system. Label information has been entered in the EDSA PALADIN Designbase program, and the technical specification information is given in Figure 1.

In Figure 2, the SCADA image of the system is shared below, and the data is entered into the Simulation Program.

The cable information in the current system has been processed into the Simulation Program. Cable information is given in Table 2 and Figure 3.

The breaker information in the current system has been processed into the Simulation Program. Therefore, circuit breaker information is given in Table 3 and Figure 4.

**Table 2.** Cable Information

Cable Technical Information	Values
Cable Type:	4/0-3C-15K
Cable Material:	Copper
Cable Length (meter):	30
Cable per Phase:	1
Cable Frequency (Hz):	50

**Table 3.** Circuit Breaker Technical Information

Circuit Breaker Information	Values
Circuit Breaker Type	VD4-17-3150A
Circuit Breaker Interrupt Rating at Max Voltage	50kA
Circuit Breaker Amp Rating (Amps)	1250
Circuit Breaker Maximum Voltage (V)	17500
Circuit Breaker Frequency (Hz)	50

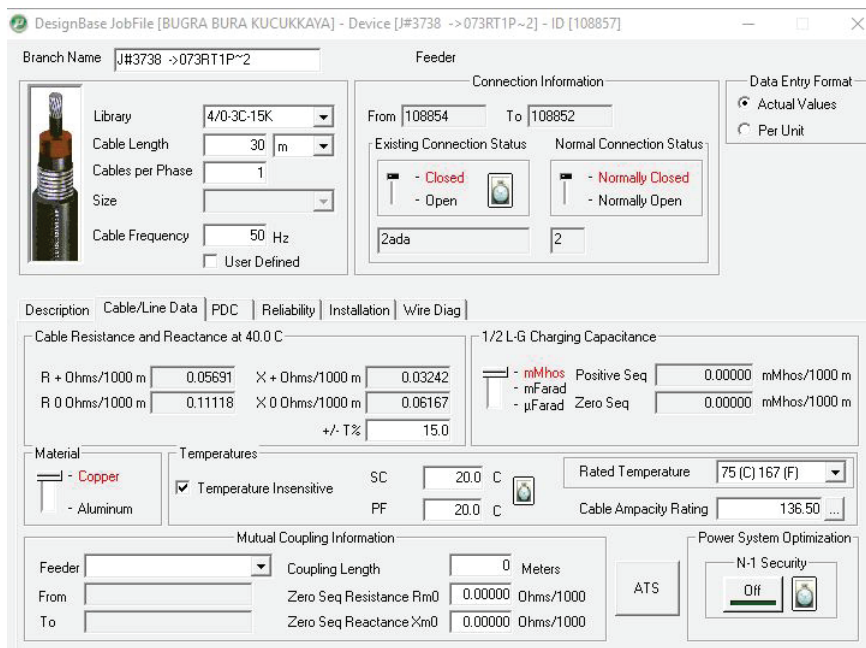

**Figure 3.** Cable information in Simulation Program.

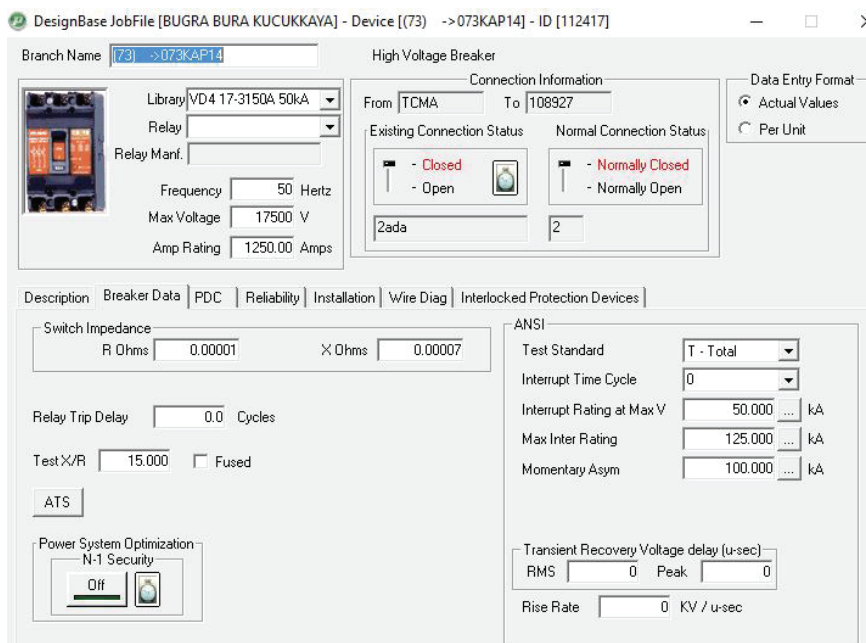

**Figure 4.** Circuit breaker information in Simulation Program.

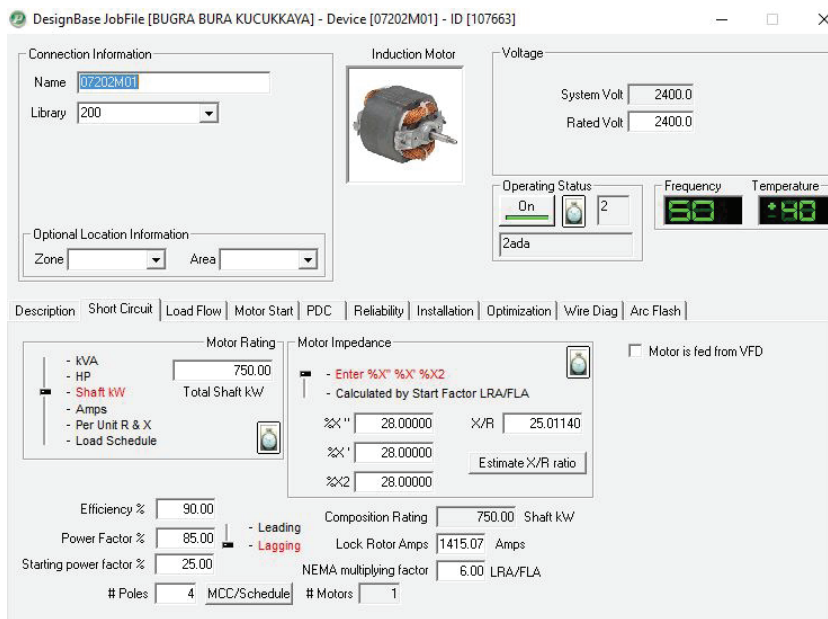

**Table 4.** The System Load Information Example

The System Load Information	Load
Type:	Induction Motor
Voltage: (V)	2400
Power: (kW)	750
Efficiency: (%)	90
Frequency (Hz):	50

Engine (Load) information in the current system has been processed into the simulation program. Therefore, motor (Load) information is given in Table 4 and Figure 5.

The power balance that occurs during the operation of these two equivalent transformers has been calculated theoretically with the analyses made in the Simulation Program. As a result of the analyses made in the system where the total load shown in Figure 6 is 4.2 MW, it has



**Figure 5.** Motor (Load) information in Simulation Program.

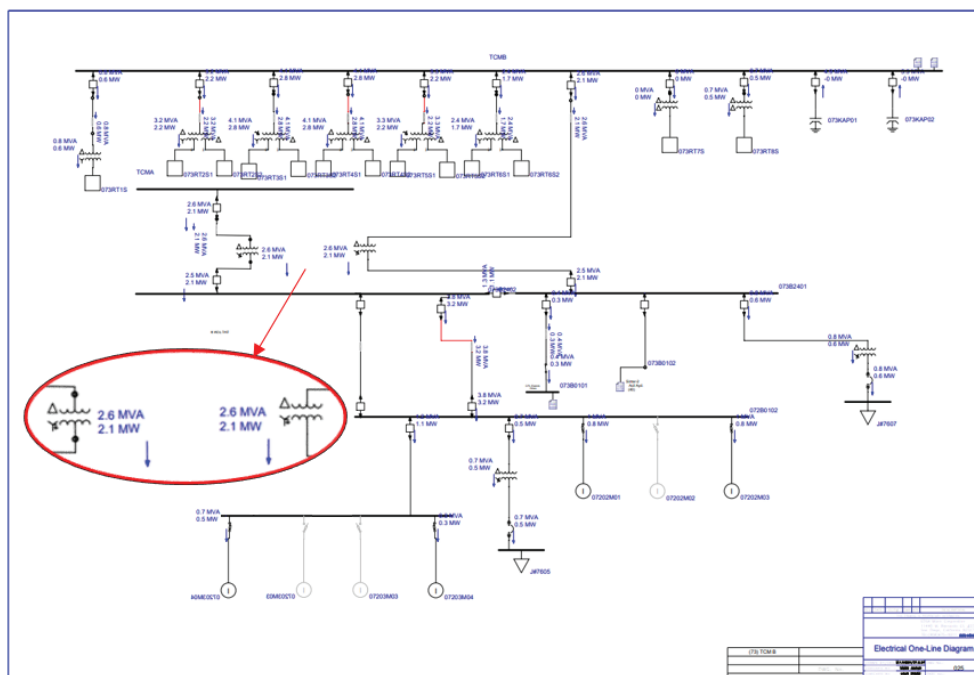

**Figure 6.** TR1-TR2 Parallel operation analysis with equivalent features.

been determined that the loads of the two equivalent transformers are 2.1 MW.

**Parallel Operation of Two Transformers with Different Relative Percent Short-Circuit Voltages**

One of the two transformers operating at the ERDEMIR TCM Substation has malfunctioned, and there is no spare transformer with the exact technical specifications. For this reason, a backup transformer was chosen, which differs only in short-circuit voltage from its technical specifications. Technical specifications of transformers with different short-circuit voltages to be operated in parallel are given in Table 5.

One of the transformers operating in parallel failed. Since there was no other transformer with equivalent technical specifications, the transformer with the closest technical specifications that met the parallelism conditions was selected among the spare transformers and integrated into the system. Technical information about the transformer, which will be integrated into the system instead of TR1, has

been entered into the Simulation Program, and the technical specification information is shown in Figure 7.

It has been determined from the factory test reports and technical information that the transformer newly integrated into the system has a %Uk value of 5,54. During the controls, it was observed that the parallel working conditions were met. Checkpoints are shown in Table 6.

**Table 6.** Parallel Operation Conditions Checkpoints

Checkpoints	Confirmation
Conversion Ratio and Voltage Conformity	Confirmed
Short Circuit Impedance Value Conformity	Confirmed
Power Rating Conformity	Confirmed
Vector Group Compliance Conformity	Confirmed
Frequency Conformity Conformity	Confirmed
Polarity Compliance Conformity	Confirmed
Phase Sequence Conformity Conformity	Confirmed

**Table 5.** New TR1 and TR2 Transformers Technical Information

Transformers Technical Information	New TR1 Technical Information	TR2 Technical Information
Transformer Power Rate (kVA):	6000	6000
Serial Number:	TN: 234	TN: 240
Short-Circuit Impedance (%):	5,54	6,41
Vector Group:	Dyn11	Dyn11
Primary Voltage (kV):	13,8	13,8
Secondary Voltage (kV):	2,4	2,4
Frequency (Hz):	50	50

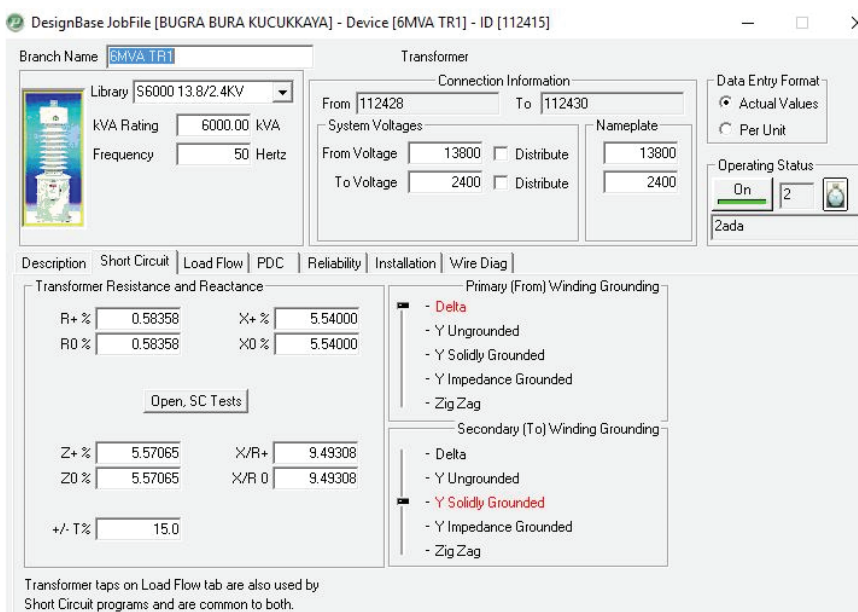

**Figure 7.** TR1 New Transformer Technical Information in Simulation Program.

The theoretical calculation of the new transformer with a different short-circuit voltage (%) value has been made, and the distribution of the current load on the transformers are shown in equations 17,18, and 19.

Calculation of the percentage of the newly formed relative short-circuit voltage during parallel operation of the transformers % $U_{k(new)}$ :

$$U_{kyeni} = \frac{S_{top}}{\frac{S_1}{U_{k1}} + \frac{S_2}{U_{k2}}} = \frac{6000 + 6000}{\frac{6000}{5,54} + \frac{6000}{6,41}} = 5,943 \quad (17)$$

The total of the current loads in the system is 3959 MW, and the newly calculated relative percent short-circuit voltage is 5,943. The loads that will occur on the transformers are given in equations 18 and 19.

$$S_{1yik} = S_{yik} \times \left( \frac{U_{kyeni}}{U_{k1}} \times \frac{S_1}{S_{top}} \right) = 3959 \times \left( \frac{5,943}{5,54} \times \frac{6000}{12000} \right) = 2123,61 \quad (18)$$

$$S_{2yik} = S_{yik} \times \left( \frac{U_{kyeni}}{U_{k2}} \times \frac{S_2}{S_{top}} \right) = 3959 \times \left( \frac{5,943}{6,41} \times \frac{6000}{12000} \right) = 1835,39 \quad (19)$$

The TR1 transformer loads 54% of the total load, and the TR2 transformer loads 46% of the total load. The maximum load value that two transformers can be loaded together in parallel operation is given. It has been determined that the current load of 3959 MW is suitable for parallel operation.

The maximum load calculation  $S_{max}$  that two transformers can load together in parallel operation is given in equation 20.

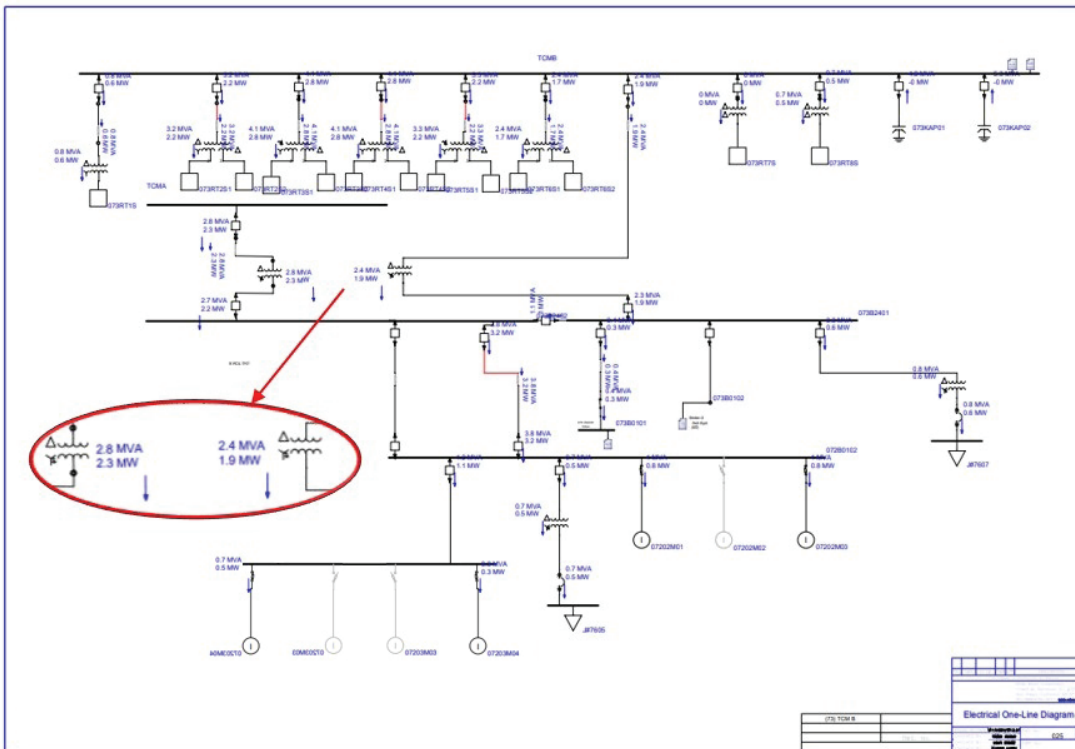

Figure 8. TR1-TR2 Parallel operation analysis with different % $U_k$  values.

Table 7. TR1-TR2 Current Values and Power Percentage Distributions with Different % $U_k$  Values

Date	Time	New TR 1 Current (A)	TR 2 Current (A)	New TR1 Power (KW)	TR2 Power (KW)	New TR1 Power (%)	TR2 Power (%)
12.01.2021	12:00:00	0,000	166,790	0,000	3.384,1	0%	100%
12.01.2021	12:00:25	96,484	68,359	1.989,000	1.376,8	59%	41%
12.01.2021	12:01:19	96,484	67,969	1.972,200	1.362,3	59%	41%
12.01.2021	12:02:01	96,484	67,969	1.982,800	1.372,9	59%	41%
12.01.2021	12:03:02	95,703	67,578	1.976,500	1.363,0	59%	41%



$$S_{\max} = \left( \frac{U_{k1}}{U_{k1}} \times S_1 \right) + \left( \frac{U_{k2}}{U_{k2}} \times S_2 \right) = \left( \frac{5,54}{5,54} \times 6000 \right) + \left( \frac{5,54}{6,41} \times 6000 \right) = 11185,64 \quad (20)$$

Transformers were entered in the Simulation Program, as shown in Figure 8, and the ratio of loads loaded in parallel operation was calculated. For example, where the total load is 4.2 MW, it has been determined that the transformers share the load percentages as TR1: 54% and TR2: 46%, respectively.

**Values Caused by Parallel Operation of Two Transformers with Different Short-Circuit Voltages**

After examining that there is no problem in the parallel operation of the transformers, the new TR1 transformer integrated into the system was connected to the busbar, where it will operate in parallel, and the preparations were completed before energizing. Transformers are energized. During parallel operation, SCADA data is taken from the system, and the load conditions of two transformers are given in Table 7.

**IEC 60076-1 Power Transformers - Part 1: General Analysis**

The transformer manufacturing is based on international technical specifications and customer needs [8]. The specifications related to transformer manufacturing are shown in Table 8. Table 9 presents the tolerances according to IEC 60076-1 to be applied to transformer losses and impedance (short-circuit voltage) when they are the subjects of the manufacturer’s guarantees [20]. This paper uses NLL, LL, and %Uk symbols for no-load losses, load losses, and impedance.

The Tolerance for Losses and Impedance is essential for maximum loading of the parallel operation of the two different short-circuit impedance transformers. Because the low %Uk value transformer will take more load than the high %Uk value transformer, the maximum load will be changed, and the transformer power capacities are affected by the situation.

Table 6 presents the tolerances according to IEC 60076-1 2011 [8] to be applied to transformer losses and impedance (short-circuit voltage) when they are the subjects of the manufacturer’s guarantees, which shows us the %Uk can change ±10% if the Uk less than %10.

According to IEC 60076-1 2011 [8], the Transformer %Uk value is 6, meaning the manufacturer can use tolerance between 5,4, and 6,6. The Short-Circuit Voltage Power Load Curve is shown in Table 10 and Figure 9.

Figure 9 shows that the transformer %Uk value can affect the maximum power load. If the %Uk values are the same, the capacity of the transformer can be used fully. For example, if the %Uk Values tolerance used by the manufacturer is ±10%, the maximum power capacity can be changed by %5. The worst-case scenario is shown in Table 11 and figure 10. If transformer 1 manufacturer used - %10 and transformer 2 manufacturer used +%10; maximum power capacity in parallel operation is affected between %9-%10.

**The Define the Method of Parallel Operation According to the Results of the Theoretical and Operational Values**

Table 9 presents the tolerances according to IEC 60076-1 2011 [8] to be applied to transformer losses and impedance (short-circuit voltage) when they are the subjects of the manufacturer’s guarantees. In section 3.4, The case study has observed that the power percentages, which

**Table 8.** Transformer Specifications

Specification	Description
IEC 60076-1	Power transformers—general
IEC 60076-2	Power transformers—temperature rise
IEC 60076-3	Power transformers—insulation levels and dielectric tests
IEC 60076-5	Power transformers—ability to withstand short-circuit
IEC 60137	Bushings for alternating voltages above 1000 V
IEC 60354	Loading guide for oil-immersed power transformers

**Table 9.** Tolerances for Losses and Impedance

Quantity	Tolerance
(a) Losses	-
(a) Total losses (NLL + LL)	+10% of the guaranteed total losses (NLL + LL)
(a) NLL (LL)	+15% of the guaranteed NLL (LL), provided that the tolerance for total losses is not exceeded
(b) Uk on principal tapping	(a) ±7.5% of the guaranteed Uk, when Uk ≥ 10% (b) ±10% of the guaranteed Uk, when Uk < 10%

Table 10. Short-Circuit Voltage Power Load Curve of 6 vs 5,4-6,6

Short-Circuit Voltage Power Load Curve of 5,4 vs 5,4-6,6							
Tr1 Power	6000	6000	6000	6000	6000	6000	6000
Tr2 Power	6000	6000	6000	6000	6000	6000	6000
Uk1	6	6	6	6	6	6	6
Uk2	5,4	5,6	5,8	6	6,2	6,4	6,6
Uk Yeni	5,684211	5,793103	5,898305	6	6,098361	6,193548	6,285714
TR1 Load	0,473684	0,482759	0,491525	0,5	0,508197	0,516129	0,52381
TR2 Load	0,526316	0,517241	0,508475	0,5	0,491803	0,483871	0,47619
S1load	5400	5600	5800	6000	6000	6000	6000
S2load	6000	6000	6000	6000	5806,452	5625	5454,545
Smax	11400	11600	11800	12000	11806,45	11625	11454,55
Max Load	0,95	0,966667	0,983333	1	0,983871	0,96875	0,954545

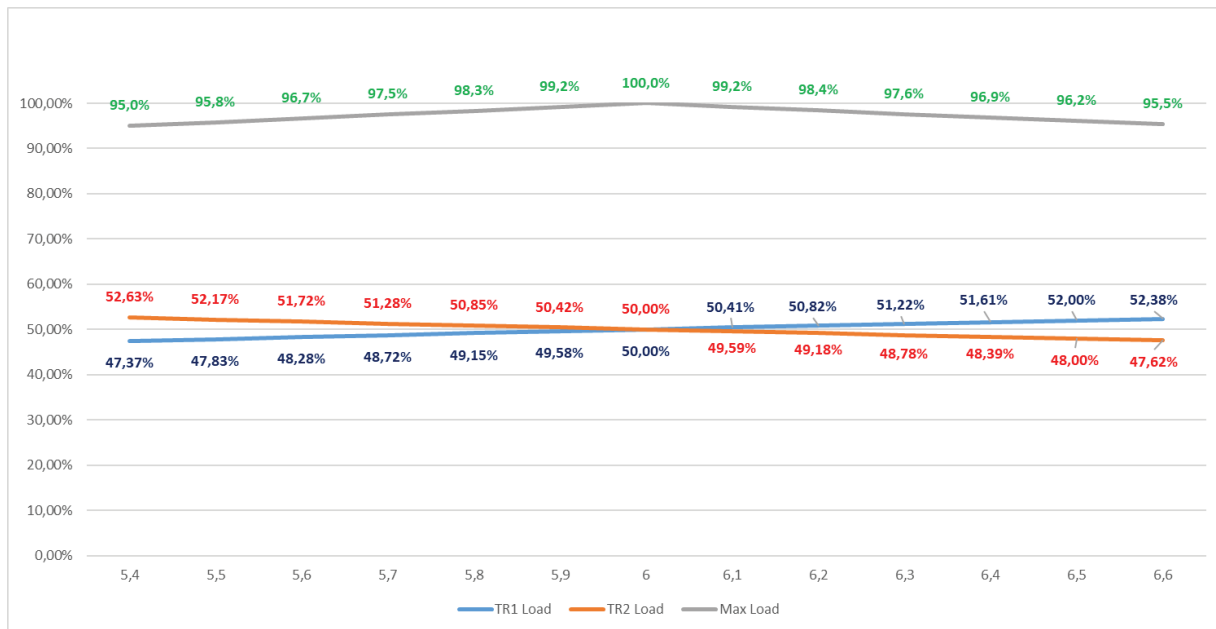

Figure 9. Short-Circuit Voltage Power Load Curve of 6 vs 5,4-6,6.

should be 54%-46%, according to the theoretical values calculated for parallel operation of transformers with different %Uk's, occur as 59%-41%. In SCADA, current and voltage values are provided with voltage and current transformers with a margin of error.

Considering the difference in SCADA, the error between the calculated value and the actual value would be 5 percent if the transformers were commissioned at the calculated maximum power. The new TR1 transformer would be loaded with more than 10 percent of its rated power, and malfunction would occur because it was overloaded. Also, the tolerance of the %Uk in IEC 60076-1 2011 [8] manufacturer can be used ±10%. The worst case scenario is shown in figure 10 if the transformer 1 manufacturer used - %10 and transformer 2 manufacturer used +%10; maximum power

capacity in parallel operation effected between %9-%10. It has been concluded that making parallel operation calculations of transformers using a safety margin of 10 percent less than the calculated value will provide safer operation. The maximum amount of power these two transformers with different short-circuit voltages can load is recalculated, and the load value calculation is shown in equation 21.

Smax: Taking into the 10% safety margin on 11185,64 kW, it is as in equation 21.

$$11185,64 \div 1,1 = 10168,76kW \tag{21}$$

It has been determined that no adverse events will occur if the transformers are operated in parallel at a value below this load. The power increase can be made by regulating

**Table 11.** Short-Circuit Voltage Power Load Curve of 5,4 vs 5,4-6,6

Short-Circuit Voltage Power Load Curve of 5,4 vs 5,4-6,6							
Tr1 Power	6000	6000	6000	6000	6000	6000	6000
Tr2 Power	6000	6000	6000	6000	6000	6000	6000
Uk1	5,4	5,4	5,4	5,4	5,4	5,4	5,4
Uk2	5,4	5,6	5,8	6	6,2	6,4	6,6
Uk Yeni	5,4	5,498	5,593	5,684	5,772	5,858	5,94
TR1 Load	50,00%	50,90%	51,80%	52,60%	53,40%	54,20%	55,00%
TR2 Load	50,00%	49,10%	48,20%	47,40%	46,60%	45,80%	45,00%
S1load	6000	6000	6000	6000	6000	6000	6000
S2load	6000	5785,7	5586,2	5400	5225,8	5062,5	4909,1
Smax	12000	11785,7	11586,2	11400	11225,8	11062,5	10909,1



**Figure 10.** Short-Circuit Voltage Power Load Curve of 5,4 vs 5,4-6,6.

the maximum load of the transformers, which were commissioned with a safety margin of 10 percent after commissioning. The maximum power shown in Equation 21 was calculated as 10168.76 kW by adding the safety margin. It has been concluded that the load will be distributed as 59% - 41% after the transformers are commissioned with this load. After the realized values, the maximum load is regulated and recalculated. It has been determined that the difference between the theory and actually formed in this direction is 4.7%, and the maximum load that can be loaded is regulated in this direction as in equation 22.

$$10168,76 \times 1,047 = 10652,99 \text{ kW} \quad (22)$$

According to the actual data, it has been determined that the maximum load that they can be loaded is 10652.99 kW. The system has been regulated by 4.7%, with the data realized after the commissioning using the safety margin of 10%. By determining the maximum load, the system can be loaded, the system continued to operate safely.

### CONCLUSION

In Power Generation Plants and transformer centers, transformers are operated in parallel. When the power of an existing transformer substation cannot meet the load in the face of ever-increasing consumption, it is more

economical to operate the transformers in parallel, which will be added in line with the load increase instead of replacing the transformers. The power of the transformer to be added to increase the power of the transformers to be used in the transformer center directly affects the cost. By feeding 100 MVA with two transformers instead of 100 MVA power with one transformer, the power of the additional transformers to be added to the system will decrease from 100 MVA to 50 MVA, thus affecting the cost considerably.

Since the backup transformer power needed by the transformers operated in parallel will be reduced by half, the cost is reduced. In addition, when the load in the system decreases, one of the two transformers is deactivated, preventing low-efficiency operation at small loads.

If the number of transformers operating in the system is high, in case of a malfunction in a transformer, the system becomes sustainable by being loaded at the rate of the power of the other operating transformer.

According to this study's theoretical and operational case of parallel operating two transformers with different relative short-circuit voltages, it is essential for the system's safety to create a minimum 10% safety margin for  $S_{max}$  over the theoretically calculated values and to regulate  $S_{max}$  according to the loading percentage that occurs after loading. Overloads that may occur are prevented.

## AUTHORSHIP CONTRIBUTIONS

Authors equally contributed to this work.

## DATA AVAILABILITY STATEMENT

The authors confirm that the data that supports the findings of this study are available within the article. Raw data that support the finding of this study are available from the corresponding author, upon reasonable request.

## CONFLICT OF INTEREST

The author declared no potential conflicts of interest with respect to the research, authorship, and/or publication of this article.

## ETHICS

There are no ethical issues with the publication of this manuscript.

## REFERENCES

- [1] Bagheri M, Naderi MS, Blackburn T, Phung T. Frequency response analysis and short-circuit impedance measurement in detection of winding deformation within power transformers. *IEEE Electr Insul Mag* 2013;29:33–40. [\[CrossRef\]](#)
- [2] Bhide RS, Kulkarni SV. Analysis of parallel operation of converters with interphase transformer. In *Proceedings of the India International Conference on Power Electronics*; 2006 Dec 19–21; Chennai, India. 2006. pp. 193–196. [\[CrossRef\]](#)
- [3] Bhide RS, Kulkarni SV, Bhandarkar P. Analysis of five-legged transformer used for parallel operation of rectifiers by coupled circuit-field approach. *IEEE Trans Power Deliv* 2011;26:607–616. [\[CrossRef\]](#)
- [4] Bhide RS, Kumbhar GB, Kulkarni SV, Koria JP. Coupled circuit-field formulation for analysis of parallel operation of converters with interphase transformer. *Electr Power Syst Res* 2008;78:158–164. [\[CrossRef\]](#)
- [5] Bramantyo S.DAHB, Munir BS, Habibie AS, Alam AS. Evaluation of 3 inter bus transformer 500/150/71 kV 500 MVA in parallel operation. In *Proceedings of the 6th International Annual Engineering Seminar 2016*; Yogyakarta, Indonesia. IEEE; 2016. pp. 266–270.
- [6] Chiulan T, Pantelimon B. (2009). "A practical example of power transformer unit winding condition assessment by means of short-circuit impedance measurement. In *proceedings of the 2009 IEEE Bucharest PowerTech*; 2009; Bucharest, Romania; 2009. pp. 1–4. [\[CrossRef\]](#)
- [7] Gurin V, Ramachandran P. *Books on power transformers in Russian-A bibliography 1924-1969*. *Transform Mag* 2021;8:68–73.
- [8] International Electrotechnical Commission. IEC 60076-1:2011. *Power transformers-Part 1: General*. Available at: <https://webstore.iec.ch/publication/588>. Accessed on May 13, 2024.
- [9] Juan COG, Pavlos SG, Rodrigo OV. A review of transformer losses. *Electr Power Component Syst* 2009;37:1046–1062. [\[CrossRef\]](#)
- [10] Kavak M. EDSA PALADIN Designbase Course, ERDEMİR. 2011. Accessed on May 14, 2024. Available at: <https://www.easypower.com/products/paladin-designbase>
- [11] Kraiczky M, Stetz T, Braun M. Parallel operation of transformers with on load tap changer and photovoltaic systems with reactive power control. *IEEE Trans Smart Grid* 2017;9:6419–6428. [\[CrossRef\]](#)
- [12] Kulkarni SA, Khaparde SV. *Transformer Engineering Design, Technology, and Diagnostics*. 2nd ed. Florida: CRC Press; 2013.
- [13] Kumar K, Kumbhar BG, Satsangi S. Assessment of effect of load models on loss-of-life calculation of a transformer using a point estimation method. *Electr Power Component Syst* 2018;46:1808–1819. [\[CrossRef\]](#)
- [14] Lawhead L, Hamilton R, Horak J. Three phase transformer winding configurations and differential relay compensation. In *proceedings of the 60th Annual Georgia Tech Protective Relay Conference*; 20016 May 2–5; Georgia. Basler Electric Company; 2006.

- [15] Liu Y, Ji S, Yang F, Cui Y, Zhu L, Rao Z, et al. A study of the sweep frequency impedance method and its application in the detection of internal winding short circuit faults in power transformers. *IEEE Trans Dielectr Electr Insul* 2015;22:2046–2056. [\[CrossRef\]](#)
- [16] Liu H, Mao C, Lu J, Wang D. Parallel operation of electronic power transformer and conventional transformer. In proceedings of the 3rd International Conference on Electric Utility Deregulation and Restructuring and Power Technologies; 2008 Apr 6-9; Nanjing, China. IEEE; 2008. pp. 1802–1808.
- [17] Macferran M. Parallel operation of transformers whose ratios of transformation are unequal. *Trans Am Inst Electr Eng* 1930;49:125–131. [\[CrossRef\]](#)
- [18] Mergen AF, Zorlu S. *Elektrik Makineleri I - Transformatörler*. İstanbul: Birsen Yayınevi; 2009. pp. 79–119.
- [19] Odođlu H. *Transformatör ve Şönt Reaktör Deneyleri*. EMO Yayınevi; 2013.
- [20] Georgilakis PS, Tsili MA, Souflaris AT. A heuristic solution to the transformer manufacturing cost optimization problem. *J Mater Process Technol* 2007;181:260–266. [\[CrossRef\]](#)
- [21] Tallaq KA, Zahhad MA. Impedance-based algorithm for the discrimination between inrush and short-circuit currents in single-phase transformers. *Electr Power Components Syst* 2003;31:593–604. [\[CrossRef\]](#)
- [22] Tan ZH, Chua KH, Lim YS, Wang L. Short circuit analyses of parallel and non-parallel transformer operations for railway power supply: A case study for third rail system. In Proceedings of the International Conference on Smart Grid and Clean Energy Technologies; 2020 Oct; Kuching, Malaysia. IEEE; 2020. pp. 155–161. [\[CrossRef\]](#)
- [23] Winders J. *Power transformers: Principles and applications*. 1st ed. Florida: CRC Press; 2002. [\[CrossRef\]](#)