



Technical Note

3D printed stacked antenna for WLAN drone communication

Aysu BELEN^{1,*} , Evrim TETİK² , Hasan BAŞAK³ 

¹Department of Iskenderun Vocational School of Higher Education, Iskenderun Technical University, Hatay, 31200, Türkiye

²Department of Electrical and Electronics Engineering, İstanbul Arel University, İstanbul, 34537, Türkiye

³Department of Electrical and Electronics Engineering, Artvin Çoruh University, Artvin, 08000, Türkiye

ARTICLE INFO

Article history

Received: 22 April 2021

Revised: 30 May 2021

Accepted: 03 November 2021

Keywords:

Microstrip Antenna; Stacked Antenna; Wide Band; Drone Communication

ABSTRACT

Unmanned Aerial Vehicle or drone technologies have spread rapidly into areas such as search and rescue, monitoring, surveillance, emergency assistance, delivery of goods, and aerial photography and video. The design of compact, low cost, and multi resonant frequency antenna models has become a critical research study for these applications. Although one of the most popular antenna designs that have such specifications are Microstrip Patch Antennas (MPA), they have the handicap of narrow operation band. Stacking is one of the techniques that not only improve the bandwidth of the antenna but also makes it possible to increase its gain and expand its operation band. Herein, design of a low cost low weight wideband Stacked (MPA) design suitable for WLAN drone communication applications is studied. By using unique features of 3D printing technology the proposed design will be prototyped for satisfying the aimed design goals. For this purpose, the antenna is simulated in CST Microwave Studio by a 3D electromagnetic based model, and maximum gain level that is approaching 9.3 dBi at 5.8 GHz frequency has been achieved. Next, the antenna design is prototyped using 3D printing technology, and a gain level of 7.5, 8.3 dBi are measured at the operating frequencies 5.2 GHz and 5.8 GHz WLAN applications. The results show that the proposed antenna achieves higher performance than its counterparts in literature based on measures such as operation bandwidth, gain, size and manufacturing costs.

Cite this article as: Belen A, Tetik E, Başak H. 3D printed stacked antenna for WLAN drone communication. Sigma J Eng Nat Sci 2023;41(3):656–664.

INTRODUCTION

Unmanned aerial vehicles (UAV), also known as drones, initially designed and developed for military applications. However, in recent years, they have spread rapidly into areas such as search and rescue, monitoring, surveillance, emergency assistance, delivery of goods, and aerial photography and video [1, 2]. Since they cost less than other options, are

easily deployed and able to hover, they became a popular choice for communication relays or aerial base stations in emergencies and public safety communications [3–6]. The traditionally designed microstrip antennas mounted on small size UAV have limited bandwidth characteristics which make them unable to transmit other type of signals other than the visual signals simultaneously [7]. This draw

*Corresponding author.

*E-mail address: aysu.belen@iste.edu.tr

This paper was recommended for publication in revised form by Regional Editor N. Özlem Ünverdi



back case frequent UAV crashes due to the limited information of ground-based pilot, whom requires other critical data such as location, altitude, direction, and flying speed alongside of visual signals in order to success a safe landing [8]. Thus, a viable antenna design solution not only must be low size, low weight, but also must have a wide operation band alongside of high gain performance.

Naturally, this spread increased the need for wireless communication systems, which led to more researchers looking for new design models of antennas that cost less, have a low profile, light weighted, compact, and broadband or multi resonant frequency [9–11]. Although Microstrip Patch Antennas (MPA) have the mentioned advantages, which made them one of the widespread antenna models, they also have a significant handicap of narrow operation bands that prevent their use in many applications [12]. Many techniques such as capacitive compensation [13, 14], reactive matching networks [15], or thicker substrates [16] have been developed in order to expand the bandwidth performance of patch antennas. However, this make the design costs more, or its radiation efficiency decreases due to considerably distorted radiation. On the other hand, stacking, which is another method for bandwidth enhancement [17–25], allows us to achieve antenna designs with high gain and wideband by stacking a parasitic patch. Recently, as the 3D printing technology developed rapidly, these devices have become not only cheap and affordable but also a popular solution for prototyping fast and accurately with a low cost [26]. Nowadays they are being used particularly for prototyping of intricate microwave designs such as Reflectarray antennas [27–30], the realization of flexible antennas [31, 32], Multilayered Dielectric Loaded Antenna (DLA) [33, 34], Quasi-Yagi Antenna [35], MPA [36], and Horn Antennas for X band applications [37].

Herein, the design of a wideband Stacked Microstrip Patch Antenna (SMPA) suitable for WLAN drone applications and its low-cost realization using 3D printing are presented. The main design goals in this work are low weight, low size antenna design that is suitable to be mounted on a drone system with low cost manufacturing technique. This can only be achieved via multi-layer or multi stacked designs. However such designs usually are heavy and hard/high cost to manufactured due to the material properties. In order to solve these challenging problems 3D printing technologies had been used. For this purpose, the antenna is simulated in CST Microwave Studio by a 3D electromagnetic based model. The geometrical design parameters of the proposed SMPA and their effects on the performance measures have been studied. After the antenna is designed with parameters that are selected optimally, it is prototyped utilizing 3D printing technology. The results obtained from the simulations of the design and the measurements of the prototype are compared. Furthermore a performance comparison study is done between the proposed design and related counterpart works in literature. It is observed from the comparison that in addition to the design achieving

a better performance than its counterparts in literature in means of operation band, size, gain performances, the realization of the proposed design can also be achieved accurately with low cost prototyping method of 3D printer technology.

Antenna Design

In this section, an SMPA antenna design as shown in Figure 1 is presented. The proposed design consist of three layers a radiating element and two parasitic patches in the second and third layers that are separated via a dielectric material, respectively. PLA (Polylactic acid) material whose permittivity varies between 1.24 and 2.71 [38], and loss value varies between 0.002~0.008 [36] is taken as the base material for 3D printing. The optimal design parameters values (Table 1) are selected using grid search technique for the SMPA to operate at WLAN frequencies of 5.2-5.8 GHz. For a better understanding the effects of variables on performance characteristic of the antenna, Figure 2 and Table 2 are presented. In order to present the importance of optimization of determination of design variables, in Figure 2, and Table 2, some of the variables are taken as variant while other parameters are taken constant equal to the mentioned optimal values. As it can be seen from the results, each of the variables have a certain level of impact on both S11 and gain characteristics of the antenna design where the determination of optimal variables value is an important factor for having high performance antenna design. The simulated gain of the antenna design with the mentioned parameter values approaches to 9.3 dBi at 5.6 GHz. In the following section, the experimental results of the 3D printed SMPA are presented, and they are compared with its own simulation results as well as its counterpart design results.

Table 1. Optimally Selected Design Variables

ϵ_1	2.2	R2	6.6 mm
ϵ_2	1.1	R3	21.2 mm
ϵ_3	1.1	R4	8 mm
W1	49.7 mm	R5	30 mm
L1	49.7 mm	H1	2 mm
Via	1.4 mm	H2	3.5 mm
R1	19.6 mm	H3	5 mm

Experimental Results of 3D Printed Stacked Antenna

In Figure 3, the 3D printed antenna is presented. RoboDual by CEL is used for prototyping of 3D printed antenna [39], the weight of the antenna is measured as 40 gram. The measurements of the 3D printed SMPA are carried out utilizing R&S®ZVL vector network analyzer a Network Analyzer with a measurement range of 9 kHz-13.5 GHz, alongside two identical antennas, A-info, LB8180,

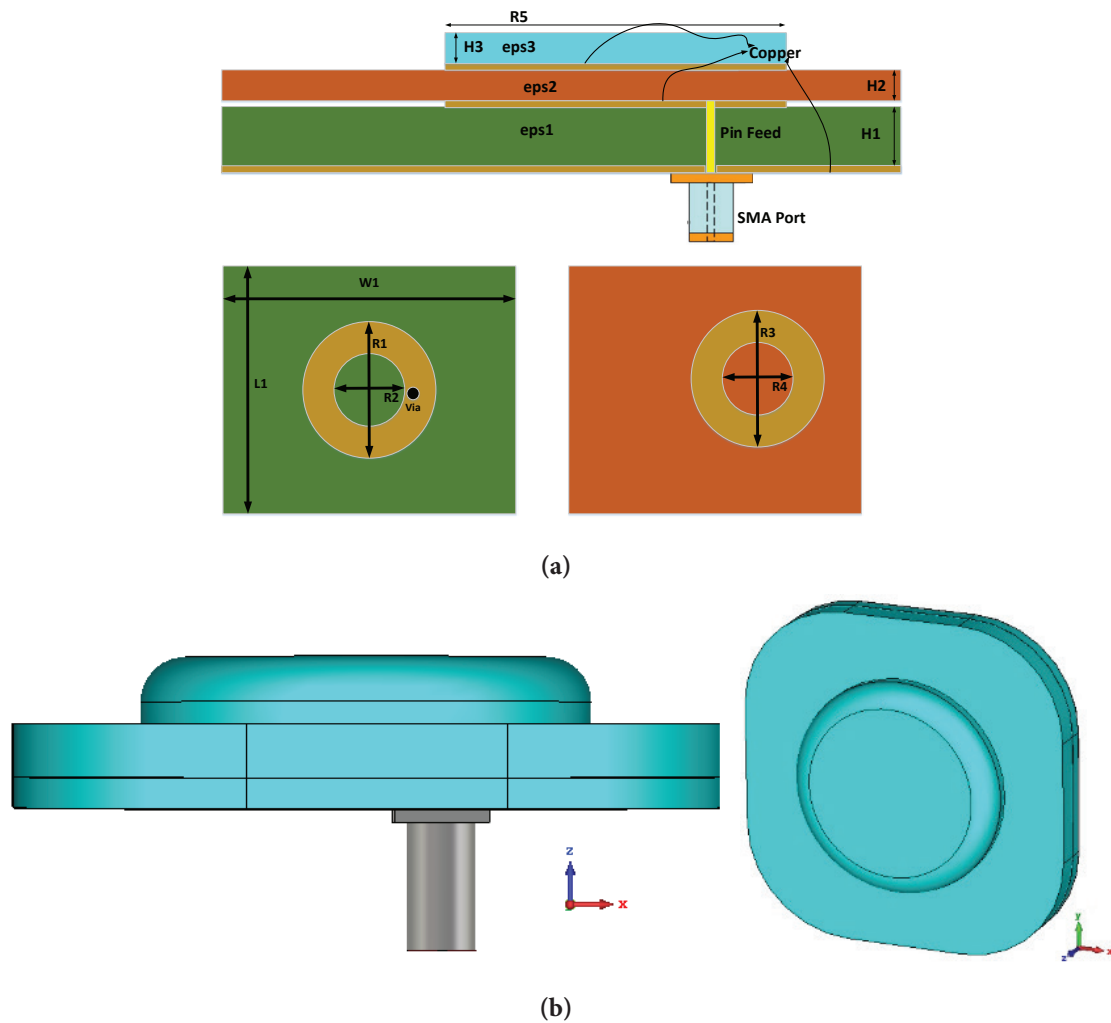

Figure 1. (a) Design schematic, (b) 3D model of SMPA.

0.8-18 GHz Broadband Horn Antenna [40–42]. The obtained simulated and experimental results are given in Figure 4. As it can be seen from the Figure 4, measured and simulated radiation patterns at 5.2 and 5.8 GHz are given alongside of $|S_{11}|$ characteristic at Figure 4 (c) from the figure, it can be observed that both simulated and measured responses are consistent. Furthermore, the performances of the proposed SMPA and its counterparts [24], [43–47] are compared in Table 3. As it can be seen from the table, the propose design achieves better operation bandwidth where the most of the counterparts achieves 200 MHz or 700 MHz operation bandwidth, the proposed antenna achieves 1 GHz band. Same can also be mentioned for the gain characteristics where, the designs with wide operation band achieves similar or better gain characteristics at the expanse of large antenna size. The only design that presents better bandwidth and size performance compared to the proposed design is [45], however it should be noted that the mentioned work is multi-layer design prototyped using high end materials of Rogers 4350B and Rogers 5800, where

the cost of manufacturing is considerable higher than the proposed cheap and ease to access PLA material.

CONCLUSION

In this work, design and realization of a 3D Printed Stacked Antenna for WLAN Drone Communication has been presented. The main goals of the work are being low size, low weight antenna design with high performance characteristics to be realized using low cost manufacturing technique of 3D printers. The proposed design has a measured gain of 7.5~8.3 dBi. Furthermore, the experimental results have been compared with both its simulation results and the performance results of counterpart designs in literature. Based on these comparisons, it can be concluded that the proposed 3D printed SMPA design achieves better performance results in means performance measures of gain, operation bandwidth, and size compared to counterpart designs, alongside having a low cost profile thanks to 3D printed technology. In feature works, it is aimed to use

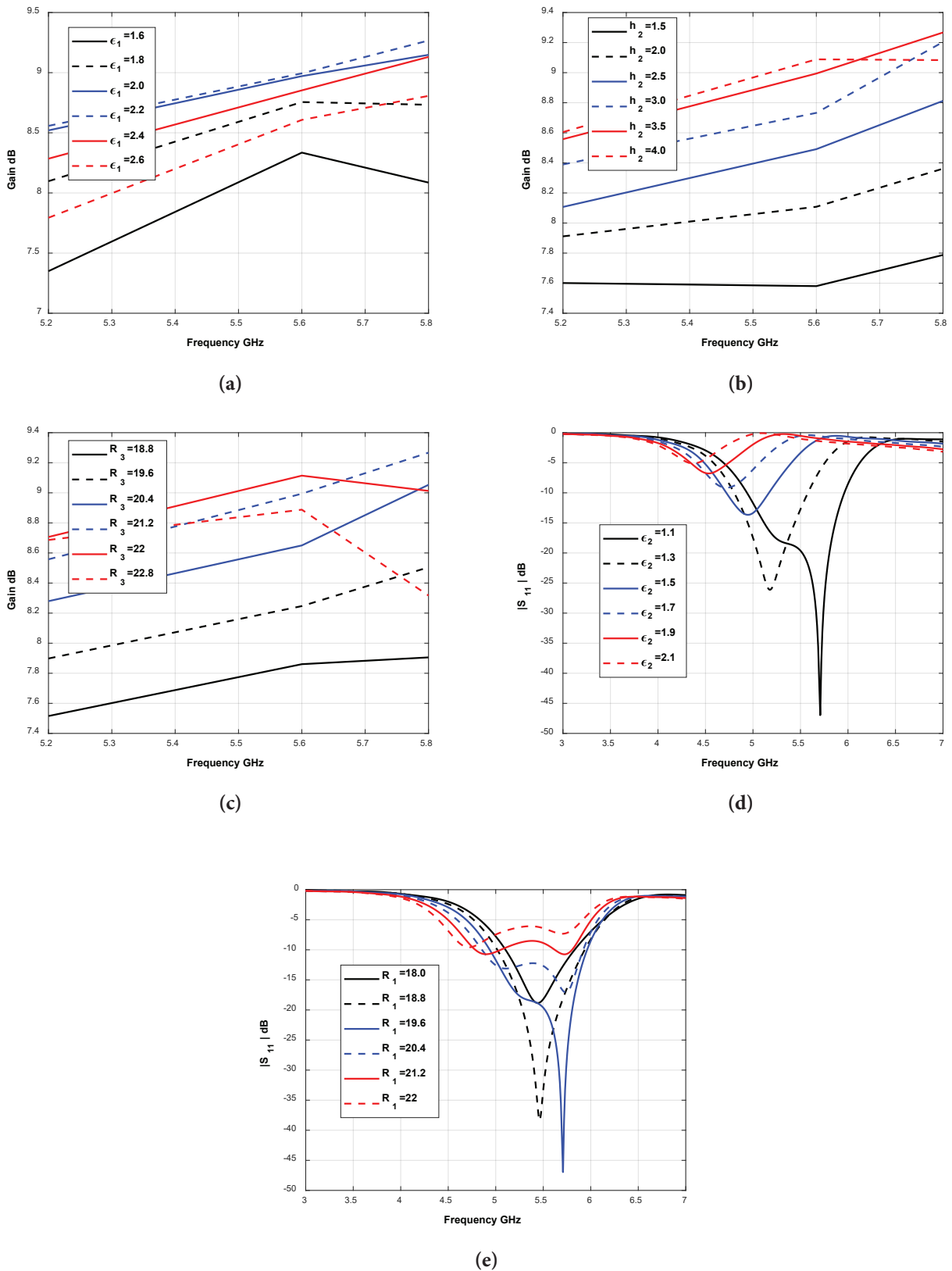
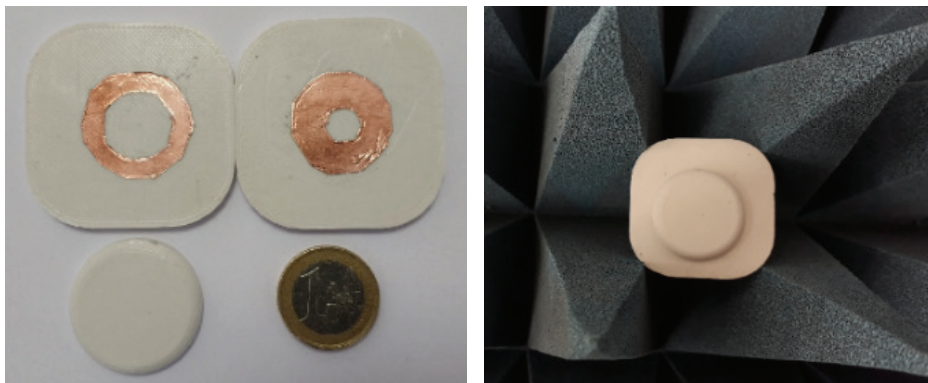

Figure 2. Gain and $|S_{11}|$ response of the SMPA antenna with respect to variation of (a) ϵ_1 , (b) h_2 , (c) R_3 , (d) ϵ_2 , (e) R_1 .

Table 2. Parametric Analysis of the SMPA Antenna

EPS1	Value	1.6	2	2.6
	Gain/ $ S_{11} $ (dB) @ 5.2 GHz	7.3 / -5.84	8.52 / -14.27	7.79 / -8.43
	Gain/ $ S_{11} $ (dB) @ 5.8 GHz	8.08 / -6.61	9.14 / -13.79	8.80 / -11.05
EPS2	Value	1.1	1.7	2.1
	Gain/ $ S_{11} $ (dB) @ 5.2 GHz	8.55 / -16.92	5.47 / -3.03	-9.3 / -0.22
	Gain/ $ S_{11} $ (dB) @ 5.8 GHz	9.26 / -19.72	-2.29 / -0.8	0.23 / -1.57
H1	Value (mm)	1.6	2.2	2.6
	Gain/ $ S_{11} $ (dB) @ 5.2 GHz	8.4 / -12.36	3.94 / -1.81	0.33 / -0.7
	Gain/ $ S_{11} $ (dB) @ 5.8 GHz	9.16 / -14.39	5.60 / -2.53	2.72 / -1.12
H2	Value (mm)	1.5	2.5	4
	Gain/ $ S_{11} $ (dB) @ 5.2 GHz	7.6 / -7.78	8.1 / -10.8	8.6 / -19.11
	Gain/ $ S_{11} $ (dB) @ 5.8 GHz	7.78 / -6.63	8.8 / -13.25	9.08 / -12.57
H3	Value (mm)	4	5	6.5
	Gain/ $ S_{11} $ (dB) @ 5.2 GHz	8.54 / -16.64	8.56 / -17.06	8.57 / -17.13
	Gain/ $ S_{11} $ (dB) @ 5.8 GHz	9.25 / -20.21	9.27 / -19.5	9.28 / -19.22
R1	Value (mm)	18	19.6	22
	Gain/ $ S_{11} $ (dB) @ 5.2 GHz	8.38 / -12.63	8.55 / -16.92	7.36 / -6.41
	Gain/ $ S_{11} $ (dB) @ 5.8 GHz	8.89 / -10.47	9.26 / -19.72	7.94 / -6.66
R3	Value (mm)	19.8	21.2	22.8
	Gain/ $ S_{11} $ (dB) @ 5.2 GHz	7.5 / -7.6	8.55 / -16.92	8.68 / -17.05
	Gain/ $ S_{11} $ (dB) @ 5.8 GHz	7.9 / -7.6	9.26 / -19.72	8.31 / -6.22



(a)

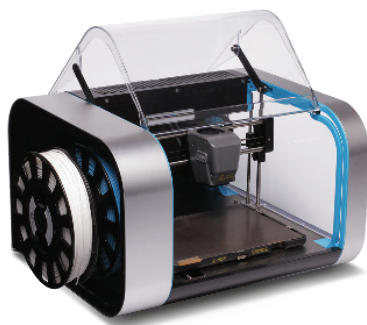

(b)

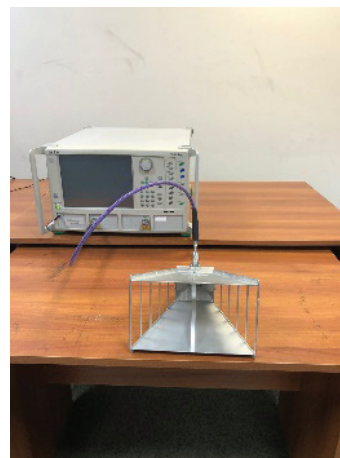

(c)

Figure 3. (a) 3D printed Antenna, (b) RoboxDual by CEL [39], (c) Measurement setup in Yildiz Technical University Microwave and Antenna Laboratories.

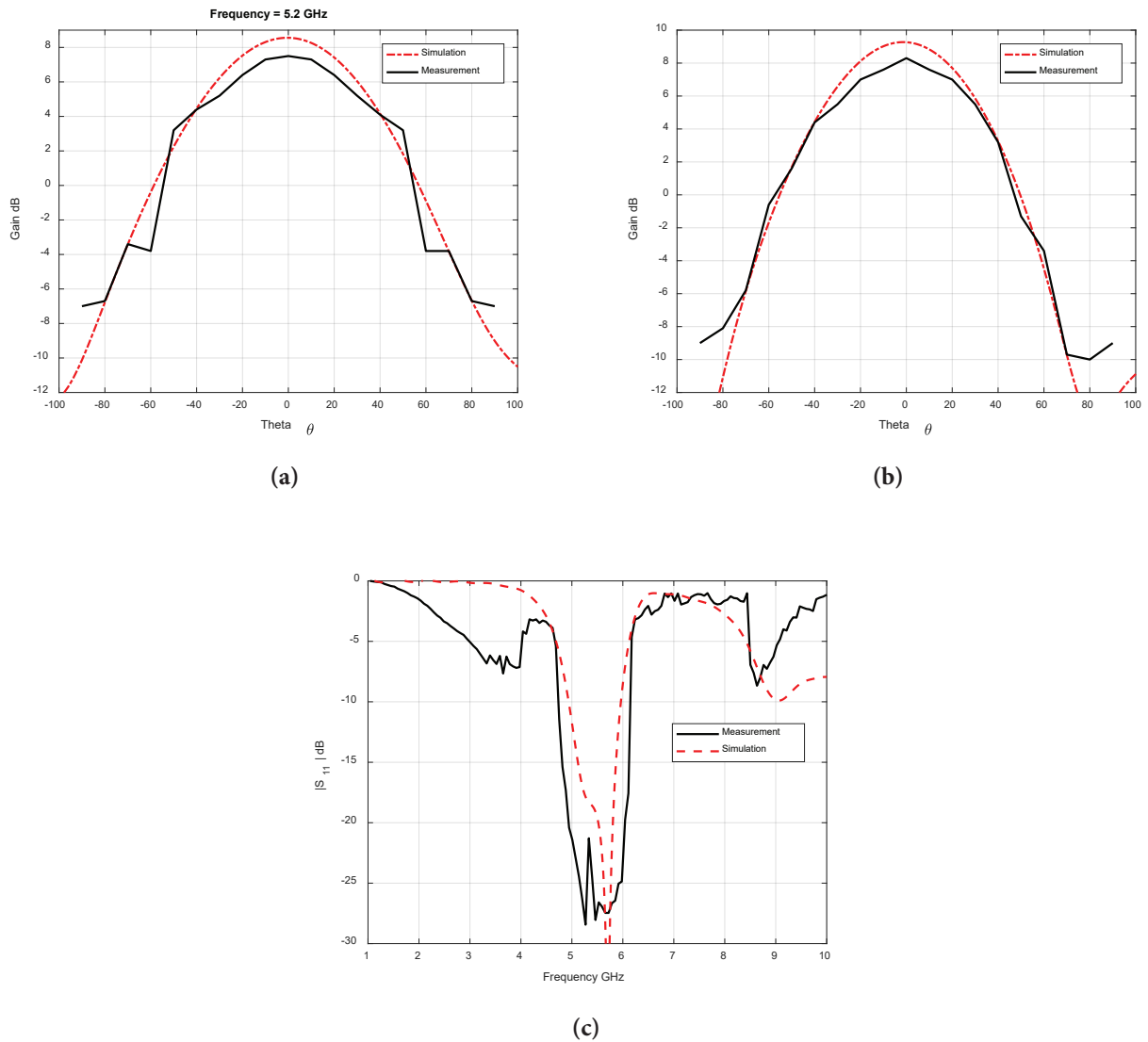

Figure 4. Measured & Simulated Radiation Patterns at (a) 5.2, (b) 5.8 GHz, and (c) $|S_{11}|$ characteristic.

Table 3. Comparison of Literature

Ref	Frequency GHz	Size (mm)	Gain dBi	-10dB BW	3 dB Beam width	Material
[24]	2.4	142x168x7.3	11.3	100MHz	20 ⁰	ABS $\epsilon_r=2.5$
[43]	1.57	87x95.2x24.8	6.5	80MHz	---	FR4
[44]	2.4	227x164x22	11	750MHz	30 ⁰	
[45]	5.2	35x35x37	7	2GHz	---	$\epsilon_{r1}=3.6$; Rogers 4350 B $\epsilon_{r2}=2.2$; Rogers 5800
[46]	4.8	22x31	4.4	210MHz	30 ⁰	Kapton polyimide substrate
[47]	2.4 / 5.2	130x130x6	5/6	200/700MHz	---	$\epsilon_r=2.2$
This study	5.2/5.8	47x47x10.5	7.5 / 8.3	1GHz	50 ⁰ / 40 ⁰	PLA, $\epsilon_1=2.2$, $\epsilon_2=1.1$, $\epsilon_3=1.1$,

this technique for design and realization of antenna structures with higher performance compared to current work but also antenna array design for ground stations of drone communication systems.

ACKNOWLEDGEMENTS

Thanks to Microwave and Antenna Laboratories of Yildiz Technical University for measurement setup, İstanbul University-Cerrahpaşa for 3D printer and to Aktif Nesor Elektronik for providing researcher licenses.

AUTHORSHIP CONTRIBUTIONS

Authors equally contributed to this work.

DATA AVAILABILITY STATEMENT

The authors confirm that the data that supports the findings of this study are available within the article. Raw data that support the finding of this study are available from the corresponding author, upon reasonable request.

CONFLICT OF INTEREST

The author declared no potential conflicts of interest with respect to the research, authorship, and/or publication of this article.

ETHICS

There are no ethical issues with the publication of this manuscript.

REFERENCES

- [1] Naidoo Y, Stopforth R, Bright G. Development of an UAV for search, rescue applications. Proceedings of the IEEE Africon'11; 2011 Sept 13–15; Victoria Falls, Zambia: IEEE; 2011. pp. 1–6. [\[CrossRef\]](#)
- [2] Hayat S, Yanmaz E, Muzaffar R. Survey on unmanned aerial vehicle networks for civil applications: a communications viewpoint. *IEEE Commun Surv Tutor* 2016;18:2624–2661. [\[CrossRef\]](#)
- [3] Palat RC, Annamalai A, Reed JH. Cooperative relaying for ad hoc ground networks using swarms. MILCOM 2005 - 2005 IEEE Military Communications Conference; 2015 Oct 17-20; Atlantic City, NJ: IEEE; 2005. pp. 1588–1594.
- [4] Gu D, Pei G, Ly H, Gerla M, Zhang B, Hong X. UAV aided intelligent routing for ad hoc wireless network in single-area theater. 2000 IEEE Wireless Communications and Networking Conference; 2000 Sept 23-28; Chicago, IL: IEEE; 2000. pp. 1220–1225.
- [5] Hauert S, Zufferey JC, Floreano D. Evolved swarming without positioning information: an application in aerial communication relay. *Auton Robots* 2009;26:21–32. [\[CrossRef\]](#)
- [6] Valcarce A, Rasheed T, Gomez K, Kandeepan S, Reynaud L, Hermenier R, et al. Airborne base stations for emergency and temporary events. In: Dhaou R, Beylot AL, Montpetit MJ, Lucani D, Mucchi L, editors. 5th International ICST Conference, PSATS 2013; 2013 Jun 27-28; Toulouse, France: Springer; 2013. pp. 13–25. [\[CrossRef\]](#)
- [7] Bhattacharjee AK, Bhadra SR, Pooddar DR, Chowdhury SK. Equivalence of impedance and radiation properties of square and circular microstrip patch antennas. *IEE Proc H Microw Antennas Propag* 1989;136:338–342. [\[CrossRef\]](#)
- [8] Balanis CA. *Antenna theory: Analysis and design*. 2nd ed. New York: John Wiley & Sons Inc; 1997.
- [9] Kim DH, Lee KH, Kim YS. Improvement of communication reliability of small UAV by a tapered stacked antenna. *ETRI J* 2006;28:796–798. [\[CrossRef\]](#)
- [10] Basilio LI, Khayat MA, Williams JT, Long SA. The dependence of the input impedance on feed position of probe and microstrip line fed patch antennas. *IEEE Trans Antennas Propag* 2001;49:45–47. [\[CrossRef\]](#)
- [11] Roy JS, Chatteraj N, Swain N. Short-circuited microstrip antennas for multiband wireless communications. *Microw Opt Technol Lett* 2006;48:2372–2374. [\[CrossRef\]](#)
- [12] Bahl IJ, Bhartia P. *Microstrip antennas*. 2nd ed. Massachusetts: Artech House, Inc; 1980.
- [13] Hall PS. Probe compensation in thick microstrip patches. *Electron Lett* 1987;21:606–607. [\[CrossRef\]](#)
- [14] Anguera J, Puente C, Borja C, Font G, Soler J. A systematic method to design single-patch broadband microstrip patch antennas. *Microw Opt Technol Lett* 2001;31:185–188. [\[CrossRef\]](#)
- [15] Pues F, Van De Capelle R. An impedance-matching technique for increasing the bandwidth of microstrip antenna. *IEEE Trans Antennas Propag* 1989;37:1345–1354. [\[CrossRef\]](#)
- [16] Chen W, Lee KF, Lee RQ. Input impedance of coaxially fed rectangular microstrip antenna on electrically thick substrate. *Microw Opt Technol Lett* 1993;6:387–390. [\[CrossRef\]](#)
- [17] Nishiyama E, Aikawa M, Egashira S. Stacked microstrip antenna for wideband and high gain. *IEE Proc Microw Antennas Propag* 2004;151:143–148. [\[CrossRef\]](#)
- [18] Targonski SD, Waterhouse RB, Pozar DM. Design of wideband aperture stacked patch microstrip antennas. *IEEE Trans Antennas Propag* 1998;46:1245–1251. [\[CrossRef\]](#)
- [19] Nasimuddin, Chen ZN. Wideband directional microstrip antennas fed by CPW loop combination. 2007 IEEE International Conference on Ultra-Wideband; 2007 Sept 24-26; Singapore: IEEE; 2007. pp. 700–702. [\[CrossRef\]](#)

- [20] Ghatak R, Mishra RK, Poddar DR. Stacked dual layer complementing sierpinski gasket planar antenna. *Microw Opt Technol Lett* 2007;49:2831–2833. [\[CrossRef\]](#)
- [21] Maikl J, Kartikeyan MV. A stacked equilateral triangular patch antenna with sierpinski gasket fractal for WLAN application. *Prog Electromagn Res Lett* 2011;22:71–81. [\[CrossRef\]](#)
- [22] Ray KP, Sevani V, Kakatkar S. Compact broadband gap-coupled rectangular microstrip antennas. *Microw Opt Technol Lett* 2006;48:2384–2389. [\[CrossRef\]](#)
- [23] Anguera J, Puente C, Borja C. A procedure to design stacked microstrip patch antenna based on a simple network model. *Microw Opt Technol Lett* 2001;30:149–151. [\[CrossRef\]](#)
- [24] Belen MA. Stacked microstrip patch antenna design for ISM band applications with 3D-printing technology. *Microw Opt Technol Lett* 2019;61:709–712. [\[CrossRef\]](#)
- [25] Egashira S, Nishiyama E. Stacked microstrip antenna with wide bandwidth and high gain. *IEEE Trans Antennas Propag* 1996;44:1533–1534. [\[CrossRef\]](#)
- [26] Zhang B, Guo YX, Zirath H. Investigation on 3-D-printing technologies for millimeter-wave and terahertz applications. *Proc IEEE* 2017;105:723–736. [\[CrossRef\]](#)
- [27] Mahouti P, Gunes F, Belen MA, Çalışkan A. A novel design of non-uniform reflectarrays with symbolic regression and its realization using 3-D printer. *Appl Comput Electromagn Soc J* 2019;34:280–285.
- [28] Belen A, Gunes F, Mahouti P, Belen MA. 3D printed wideband flat gain multilayer non-uniform reflect array antenna for X band applications, *Int J Numer Model Electron Netw Devices Fields* 2020;33:e2753. [\[CrossRef\]](#)
- [29] Mahouti M, Kuskonmaz N, Mahouti P, Belen MA, Palandoken M. Artificial neural network application for novel 3D printed nonuniform ceramic reflectarray antenna. *Int J Numer Model Electron Netw Devices Fields* 2020;33:e2746. [\[CrossRef\]](#)
- [30] Nayeri P, Liang M, Sabory-Garci RA, Tuo M, Yang F, Gehm M, et al. 3D printed dielectric reflectarrays: low-cost high-gain antennas at sub-millimeter waves. *IEEE Trans Antennas Propag* 2014;62:2000–2008. [\[CrossRef\]](#)
- [31] Mirzaee M, Noghianian S, Wiest L, Chang Y. Developing flexible 3D printed antenna using conductive ABS materials. 2015 IEEE International Symposium on Antennas and Propagation & USNC/URSI National Radio Science Meeting; 2015 Jul 19–24; Vancouver, Canada: IEEE; 2015. pp. 1308–1309. [\[CrossRef\]](#)
- [32] Ahn BY, Duoss EB, Motala MJ, Guo X, Park SI, Xiong Y, et al. Omnidirectional printing of flexible, stretchable, and spanning silver microelectrodes. *Science* 2009;323:1590–1593. [\[CrossRef\]](#)
- [33] Mahouti P, Belen MA, Gunes F, Yurt R. Design and realization of multilayered cylindrical dielectric lens antenna using 3D printing technology. *Microw Opt Technol Lett* 2019;61:1400–1403. [\[CrossRef\]](#)
- [34] Belen A, Gunes F, Mahouti P, Palandoken M. A novel design of high performance multilayered cylindrical dielectric lens antenna using 3D printing technology. *Int J RF Microw Comput-Aided Eng* 2020;30:e21988. [\[CrossRef\]](#)
- [35] Belen MA, Mahouti P. Design and realization of quasi yagi antenna for indoor application with 3D printing technology. *Microw Opt Technol Lett* 2018;60:2177–2181. [\[CrossRef\]](#)
- [36] Mahouti P. Cost efficient prototyping of microstrip patch antenna using 3D printing technology. *J Eng Sci Des* 2019;7:473–479. [\[CrossRef\]](#)
- [37] Toy YC, Mahouti P, Gunes F, Belen MA. Design and manufacturing of an X-band horn antenna using 3-D printing technology. In: Hacıoglu A, Unal NF, Altan O, Yorukoglu M, Yilidiz MS, editors. 2017 8th International Conference on Recent Advances in Space Technologies; 2017 Jun 19–22; Istanbul, Turkey: IEEE; 2017. pp. 195–198. [\[CrossRef\]](#)
- [38] Zhang S, Njoku CC, Whittow WG, Vardaxoglou JC. Novel 3D printed synthetic dielectric substrates, *Microw Opt Technol Lett* 2015;57:2344–2346. [\[CrossRef\]](#)
- [39] RoboxDual by CEL. Available at: <https://cel-uk.com/shop/roboxdual-by-cel-a-dual-material-3d-printer/>. Last Accessed Date: 07.07.2021
- [40] Rohde & Schwarz. R&S®ZVL vector network analyzer. Available at: https://www.rohde-schwarz.com/sg/product/zvl-productstartpage_63493-9014.html Accessed on May 21, 2023.
- [41] A-info. LB8180, 0.8-18 GHz broadband horn antenna. Available at: http://www.ainfoinc.com/en/p_ant_h_brd.asp, Accessed on August 15, 2017.
- [42] Belen MA, Gunes F, Mahouti P, Belen A. UWB gain enhancement of horn Antennas using miniaturized frequency selective surface. *Appl Comput Electromagn Soc J* 2018;33:997–1002.
- [43] Tapas M, Susamay S, Rowdra G, Chaudhuri SRB. A novel hexagonal wideband circularly polarized stacked patch microstrip antenna. *Microw Opt Technol Lett* 2015;57:2548–2554. [\[CrossRef\]](#)
- [44] Wadkar S, Hogade B, Chopra R, Kumar G. Broadband and high gain stacked microstrip antenna array. *Microw Opt Technol Lett* 2019;61:1882–1888. [\[CrossRef\]](#)
- [45] Katyal, A., Basu, A. (2017) Compact and broadband stacked microstrip patch antenna for target scanning applications, *IEEE Antennas Wirel Propag Lett* 2019;16:381–384. [\[CrossRef\]](#)

- [46] Li WT, Hei YQ, Grubb PM, Shi X, Chen RT. Inkjet printing of wideband stacked microstrip patch array antenna on ultrathin flexible substrates. *IEEE Trans Compon Packaging Manuf Technol* 2018;8:1695–1701. [\[CrossRef\]](#)
- [47] Liang Z, Liu J, Li Y, Long Y. A dual-frequency broadband design of coupled-fed stacked microstrip monopolar patch antenna for WLAN applications. *IEEE Antennas Wirel Propag Lett* 2016;15:1289–1292. [\[CrossRef\]](#)