



## Research Article

# Design, development, and analysis of a box type solar cooker with optimally reflecting side walls

Hemish VAIDYA<sup>1,2,\*</sup>, Manish RATHOD<sup>2</sup>, Salim CHANNIWALA<sup>2</sup>

<sup>1</sup>Department of Mechanical Engineering, Government Engineering College, Valsad, Gujarat, 396001, India

<sup>2</sup>Department of Mechanical Engineering, Sardar Vallabhbhai Patel National Institute of Technology, Surat, Gujarat, 395007, India

## ARTICLE INFO

### Article history

Received: 11 July 2022

Revised: 07 September 2022

Accepted: 08 September 2022

### Keywords:

Solar Cooker; Optimally Inclined Sidewalls; Figure of Merit; Pot Temperature; Plate Temperature

## ABSTRACT

A novel inclined sidewall box-type solar cooker is constructed, and its performance is evaluated. The Opto-geometrical design of the cooker was designed for Surat, a city in India. The design is modified by optimizing the inclination angles of the sidewalls so that an optimal thermal response may be generated by reflecting sun rays from the sidewalls, and the performance of the solar cooker is enhanced. The optimized sidewall angles due south, due north, due east, and due west are designed to be 67.3°, 22.69°, 35.44° and 35.44° respectively and side walls are made reflective with reflecting Aluminium sheets. The results are compared with a conventional cooker. The thermal performance of the newly built solar cooker was evaluated, and the merit  $F_1$  for no-load circumstances and the merit  $F_2$  for various loading conditions were determined. The results show that the maximum plate temperature, the figure of merit  $F_1$  and the maximum pot temperature of the newly developed solar cooker with optimally reflecting sidewalls during load test are higher than that of a conventional cooker. The maximum plate temperature is found to be 76°C and 65°C in newly designed and conventional solar cookers, respectively. The temperatures are found to be about 16% more from 11:30 pm to 2:00 pm in the newly designed cooker compared to the conventional cooker. The maximum value of Figure of merit  $F_1$  is found to be 0.15 and 0.11 in newly designed and conventional solar cookers. The maximum value of Figure of merit  $F_2$  is found to be 0.59 and 0.30 in newly designed and conventional solar cookers. The maximum value of pot temperature is found to be 86°C and 60°C for newly designed and conventional solar cookers, respectively, during the load test, which is about 43% more in the newly designed cooker than the conventional cooker. The highest cooking temperature in the newly designed cooker was maintained at 90 °C for about 2 hours, and that in the conventional cooker was maintained at 60 °C for about 2 hours. In addition, the cooking test demonstrates that the food is thoroughly cooked in the newly built solar cooker, while it was discovered undercooked in the conventional cookerC thickness, respectively without heat recovery. The operating conditions and optimized geometric factors, based on result analysis and comparison, are discussed in detail.

**Cite this article as:** Vaidya H, Rathod M, Channiwala S. Design, development, and analysis of a box type solar cooker with optimally reflecting side walls. J Ther Eng 2023;9(3):1–647.

### \*Corresponding author.

E-mail address: hemish2000@gmail.com, mkr@med.svnit.ac.in, sac.med.svnit@gmail.com

This paper was recommended for publication in revised form by Assigned Editor Ahmet Selim Dalkılıç



## INTRODUCTION

Solar energy is the radiant energy produced by the sun. Solar cookers are devices used to entrap the sun's radiant energy for cooking. Taner and Dalkilic [1] performed a feasibility study of solar energy-techno economic analysis and their results figure out the efficient result for establishing a solar energy plant in a village in Turkey. Solar cooking is one of the significant applications of solar energy, and it can replace the conventional technologies of cooking, as suggested by Pohekar [2] and Farooqui [3]. In villages of India, cooking is done majorly by burning wood or cow dung. Solar cooking must substitute them for reducing health risks and the destruction of forests. Large numbers of solar cookers have been developed in various countries. Solar cookers can be classified into two major categories considering how thermal energy is transferred from the sun to the cooking vessel: focused or direct and box or indirect. According to Sansaniwal [4], considering the configuration of the device, they can be classified into four types: box type, concentrating solar cooker, collector cooker, and panel cooker. Focusing-type solar cookers cook at high temperatures quicker than box-type cookers, but they have a high initial cost and need expert personnel to operate as per Abou-Ziyan [5]. Panel cookers have high maximum working temperatures and can function as multiple cookers simultaneously. As a result of their greater reliance on reflected beams, their overall performance in cloudy conditions is extremely subpar. A parabolic dish directs a concentrated solar radiation beam on the bottom of a blackened cooking pot used cooking. Yettou et al. [6] generated maps of receiver temperature of parabolic collector for solar food cooking. A monitoring system is necessary to follow the sun's movement and adjust the focus for optimal solar energy reflection, according to Algifri [7].

The box-type solar cooker is the simplest of all types of solar cookers. Box-type solar cookers prepare food by exploiting the greenhouse effect. Short-wave radiation can flow through a clear glass or plastic cover that is placed over the insulated box. This radiation is absorbed by the inside black-coated box. Energy is reradiated at longer wavelengths as the temperature of the inner tray rises. The glass cover prevents longwave radiation from passing through. The temperature of the box rises until it reaches an equilibrium temperature where heat losses balance the solar energy supply. A plane reflector is connected to the cooker to improve its performance. This kind of cooker can accommodate many pots of food. Because the food gets cooked at low temperatures, it does not burn. It is simple to transport due to its lightness. Due to above reasons, the box type solar cooker is used for present study. Various researchers have carried out experiments on the solar cooker for its performance and analysis. The solar cooker is made up of many components, each of which has a substantial impact on the solar cooker's performance.

The use of a solar cooker has several drawbacks, the most significant of which are that it takes a considerable amount of time to cook, that it is not always accessible, and that it is much less effective at cooking when there is a reduced amount of sunshine. Therefore, there is a requirement to improve the performance of the solar cooker to eliminate the drawbacks that have been discussed above. The use of nanofluids, modifying the geometry of solar cookers, making technical changes and implementations for improving the use of solar energy, and use of thermal storage are a few strategies to increase the performance of solar cookers. Numerous researchers, such as Aramesh et al. [8], Omara et al. [9], Khatri et al. [10], Sawarn et al. [11], and have examined solar cooking in all of its facets. Alajingi and Marimuthu [12] discussed about the recent advancements of domestic solar appliances. Nkhonjera et al. [13] focused their research on determining the optimal container shape for a heat storage medium that could be used in solar cooking. According to the study conducted by Panchal et al. [14], latent heat storage material is able to keep the heat for an additional three to four hours than sensible heat storage material. Arunachala and Kundapur [15] suggested an improved cooker design for locating it indoors, reducing costs, and gaining social acceptance. Komolafe et al. [16] investigated the design, fabrication, and thermal evaluation of a solar cooking system integrated with an Arduino-based tracking device and sensible heat storage (SHS) materials. Asrori et al. [17] conducted the study to investigate the thermal performance of solar cooker using a spot Fresnel lens for concentrators of solar thermal energy. Cuce et al. [18] experimented with enhancing the performance figures of solar cookers through latent heat storage and low-cost booster reflectors. Milikias et al. [19] designed, developed, and experimentally tested the performance of an improved box-type solar cooker with thermal energy storage.

It is to be noted from the literature that the optical efficiency and heat capacity of the solar cooker are two of the many essential design elements that determine its thermal performance. The angle of incidence of solar radiation, the number of covers (glazing), the material for covers, the coating of the stove absorber plate, and other parameters affect the optical efficiency of a solar collector.

Effects of glazing and reflectors have been reported by Mehta and Channiwala [20] on box-type and triangular cookers. In their study, the extreme plate and air mass temperatures of the triangular cooker were higher than that of the box-type solar cooker for both load and no-load conditions. Heat transfer coefficient and top heat loss coefficient were less in the rectangular enclosures by 31% and 7%, respectively, as compared to trapezoidal enclosures. Channiwala and Doshi [21] presented the top loss coefficient and overall heat loss coefficient as a function of the plate temperature and ambient temperature difference for the feasible functioning range of box-type solar cookers considering the factors of wind speed and glass cover number. They also suggested a correlation for wind top loss

coefficient. A thermal testing method proposed by Mullick et al. [22] for finding the performance of a double-glazed box-type solar cooker concluded that for better performance, a high ratio of optical efficiency to overall heat loss is required. Investigations on roughness element geometries by Gawande [23], natural heat transfer coefficient by Kumar [24], and weight analysis by Goswami et al. [25] were carried out to study their effect on the performance of the solar cooker.

Many researchers proposed various mathematical models and designs for solar cooking, namely a model with a booster reflector by Harmim et al. [26], different conditions predicting solar cooker performance by Pejack [27], heat transfer on box-type solar cookers with internal reflectors by Terres et al. [28], and forecasting cooking power characterized by three regulated parameters (coefficient of overall heat transfer, intercept area, and thermal conductivity of absorber plate) and three unregulated factors (solar insolation, temperature variation, and load dispersal) by Funk and Larsen [29]. Hajibeigy et al. [30] showed by mathematical modelling that with better design, efficiency of solar panels operating in non-optimal conditions can be improved. Vaidya and Channiwala [31] developed a mathematical model for box type solar cooker including thermal contact resistance.

A novel design was proposed by Das et al. [32] in which solar energy is received indirectly by the cooking pot. As a booster reflector, it is equipped with an irregular parabolic concentrator that concentrates solar energy captured on the horizontal aperture onto the vertical absorber plate. El-Sebaii et al. [33] investigated the influence of variables

such as plate thickness, vessel emissivity, and insulation thickness on cooking time. Their research showed that black paint on vessels might be avoided by using weathered stainless steel or aluminum vessels and a transitory mathematical model for a box-type solar cooker with a stepped outer reflector pivoted at the top of the cooker was provided. Many researchers made changes to the concept, such as developing a solar cooker with internal reflectors [34], a truncated pyramid solar box cooker [35], and the introduction of mirrors [36]. The effects of various mirror configurations and placements and mirror inclination angles have also been studied by [37,38]. Sethi et al. [39] observed temperatures of up to 100 °C using a solar cooker with an inclined structure with 3 levels and booster mirrors. Mahavar et al. [40] prepared two servings of rice in 4.75 hours using a removable aluminum partition to split a cylindrical cooking pot into four similar portions. Shaik et al. [41] evaluated different transparent glazing materials, such as acrylic, low-iron, medium-iron, and high-iron glasses, had their sunlight transmission characteristics.

Thus, from the literature review, it can be stated that various researchers have tried to modify the design of the cooker and improve the performance of the solar cooker. A list of work done by various researches in modification of design of solar cooker is given in Table 1.

In most of the designs described in the literature, the cooking pot receives heat from the lid through the glass cover and the bottom through the absorber plate. It is possible to improve the energy acquisition by giving the sidewall an incline and making it reflective.

**Table 1.** Work of various researchers on modification of design of solar cooker

Sr No	Name of Investigator	Modification in Design of Solar Cooker	Outcomes
1	Mehta and Channiwala [20]	Comparison between box-type and triangular cookers	Heat loss coefficient less by 17%
2	Harmim et al. [26]	double exposure solar box cooker with a parabolic reflector	$F_1 = 0.16$
3	El-Sebaii et al. [33]	Multi-step inner reflectors.	$F_1 = 0.19; F_2 = 0.38$
4	Kahsay et al. [34]	Extra internal reflectors placed at 60°	Increase in temperature by 22%
5	Kumar et al. [35]	a truncated pyramid solar box cooker	$F_1 = 0.117; F_2 = 0.467$
6	Zafar et al. [42]	L-shaped absorber plate with one internal (bottom) and two external plane reflectors	$F_1 = 0.12; F_2 = 0.26$
7	Guidara et al. [43]	Four outer mirror reflectors	$F_1 = 0.07$ to 0.14
8	Coccia et al. [44]	Several reflectors to make funnel shape cooker.	$F_1 = 0.39; F_2 = 0.26$
9	Cuce [45]	Triangular, semi-circular, and trapezoidal microporous absorbers	Plate temperature obtained: Conventional absorber -110 °C, triangular - 134.1°C, semicircular-146.6 °C trapezoidal-151.1 °C
10	Amer E H [46]	Double exposure solar cooker in which the absorber is exposed to solar radiation from the top and the bottom sides	Cooking time reduced by 30-60 minutes.

An attempt is made by El Sebaï [33] by making stepped internal reflectors and by Kahsay [34] by adding extra reflectors at  $60^\circ$  inclinations to improve energy from the sides also. The multi-step inner reflectors are designed by El Sebaï using triangular and rectangular pieces of ordinary plane mirrors in a three-step fashion. The lower, middle and upper steps are fixed to create angles of  $30^\circ$ ,  $45^\circ$ , and  $75^\circ$  with respect to the horizontal, respectively. The cooking vessel is supported by a holder that was custom-made for it. It appears to be a pan that is hung upside down from two copper bars that are fastened to the outside of the wooden box. Another plane mirror facing the bottom of the cooking vessel is provided at the bottom of the device. As a result, after being reflected by the side mirrors, some of the rays may be reflected by the mirror that is located at the bottom of the vessel. Because of this, there is a rise in the level of radiation intensity within the cooking vessel as per El Sebaï. Thus, there is solar radiation from the top and bottom of the vessel. Some part of reradiated solar rays gives energy from the sides and some part from the bottom. But the amount of solar energy from the sides is less as the angle of inclination is not optimized for maximum solar radiation. Also, a complex geometry for multistep inner reflectors makes the construction of the solar cooker difficult and costly.

To get energy from the sidewalls Kahsay et al. gave the  $60^\circ$  inclinations on front and side walls. They concluded that more energy can be obtained from the sidewalls also if the inclination of the sidewalls is optimized. Hence, in the present research work, as a novel component, a new cooker with optimized inclined side walls is designed and developed. The optimized sidewall angles due south, due north, due east, and due west are calculated as  $67.3^\circ$ ,  $22.69^\circ$ ,  $35.44^\circ$ , and  $35.44^\circ$ , respectively.

The inclination given to the optimized reflective sidewalls will reflect the solar radiation falling on the sidewalls in the direction parallel to the horizontal absorber plate and will provide more heat to the pots through the sides, enhancing the performance of the solar cooker. The optimization of sidewall inclination angle is not observed in the literature, and the authors consider this a novel approach. Hence in the present work, a box-type solar cooker is designed and developed with optimally reflecting sidewalls. The results are compared with the conventional cooker.

### Design Modifications in New Developed Solar Cooker

If a solar cooker is able to successfully prepare food throughout the winter, in addition to the other performance factors that need to be examined, the solar cooker has the potential to be regarded as an excellent solar cooker. Hence the modification in the design is based on the insolation available in December at the location of Surat when the solar insolation available is least [47]. Initially, the absorber plate area required for cooking is calculated as suggested by Goswami et al. [25] and Vaidya et al. [48]. The incident angle is calculated on the horizontal surface of the absorber

plate as shown in Figure 1 and all the four sidewalls of the solar cooker as shown in Figure 2 at solar noon considering the date of 21<sup>st</sup> December. Then the inclination angle of all the side walls is changed so that the reflected sun rays from the wall become horizontal and remain parallel to the base. Hence the surface should be tilted so that  $\theta = 90 - \beta$  or  $\beta = 90 - \theta$ .

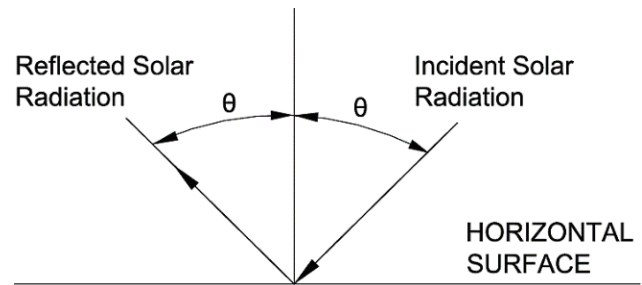

Figure 1. Incidence angle at Horizontal Surface.

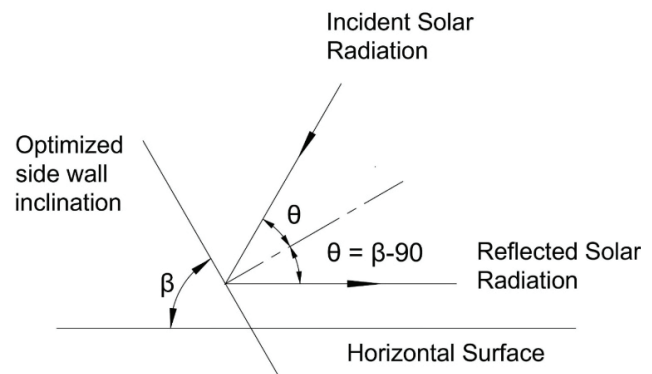

Figure 2. Optimized Inclination Angle.

Cosine of angle between an incident beam of flux  $I_{bn}$  and the normal to a plane surface,  $\theta$ , can be given by the following equation [49].

$$\begin{aligned} \cos \theta = & \sin \varphi (\sin \delta \cos \beta + \cos \delta \cos \gamma \cos \omega \sin \beta) \\ & + \cos \varphi (\cos \delta \cos \omega \cos \beta - \sin \delta \cos \gamma \sin \beta) \quad (1) \\ & + \cos \delta \sin \gamma \sin \omega \sin \beta \end{aligned}$$

For the location of Surat, latitude  $\varphi = 21.170$

The declination angle  $\delta$  can be calculated using the following formula [49]

$$\delta = 23.45 \sin \left[ \frac{360}{365} (284 + n) \right] \quad (2)$$

For the 21<sup>st</sup> of December, the number of days of the year,  $n = 355$ , and hence

The declination angle  $\delta = -23.45$

Considering the time at solar noon, i.e., hour angle  $\omega = 0^\circ$

(a) For side wall facing due south  $\gamma = 0^\circ$

Taking  $\theta = 90 - \beta$

$$\begin{aligned} \cos(90 - \beta) &= \sin 21.17(\sin -23.45 \cos \beta + \cos -23.45 \cos 0 \cos 0 \sin \beta) \\ &+ \cos 21.17(\cos -23.45 \cos 0 \cos \beta - \sin -23.45 \cos 0 \sin \beta) \\ &+ \cos -23.45 \sin 0 \sin 0 \sin \beta \end{aligned} \quad (3)$$

$$\beta = 67.30^\circ$$

(b) For side wall facing due south  $\gamma = 180^\circ$

$$\begin{aligned} \cos(90 - \beta) &= \sin 21.17(\sin -23.45 \cos \beta + \cos -23.45 \cos 180 \cos 0 \sin \beta) \\ &+ \cos 21.17(\cos -23.45 \cos 0 \cos \beta - \sin -23.45 \cos 180 \sin \beta) \\ &+ \cos -23.45 \sin 180 \sin 0 \sin \beta \end{aligned} \quad (4)$$

$$\beta = 22.69^\circ$$

(c) For side wall facing due east  $\gamma = 90^\circ$

$$\begin{aligned} \cos(90 - \beta) &= \sin 21.17(\sin -23.45 \cos \beta + \cos -23.45 \cos 90 \cos 0 \sin \beta) \\ &+ \cos 21.17(\cos -23.45 \cos 0 \cos \beta - \sin -23.45 \cos 90 \sin \beta) \\ &+ \cos -23.45 \sin 90 \sin 0 \sin \beta \end{aligned} \quad (5)$$

$$\beta = 35.44^\circ$$

(d) For side wall facing due west  $\gamma = 270^\circ$

$$\begin{aligned} \cos(90 - \beta) &= \sin 21.17(\sin -23.45 \cos \beta + \cos -23.45 \cos 90 \cos 0 \sin \beta) \\ &+ \cos 21.17(\cos -23.45 \cos 0 \cos \beta - \sin -23.45 \cos 90 \sin \beta) \\ &+ \cos -23.45 \sin 270 \sin 0 \sin \beta \end{aligned} \quad (6)$$

$$\beta = 35.44^\circ$$

Thus, all four sidewalls are inclined as the calculated angles. The dimensional details of the newly developed

solar cooker are shown in Figure 3. The assembly drawing for the newly designed solar cooker is shown in Figure 4.

### Fabrication of New Designed Solar Cooker

Initially, the solar cooker is fabricated as per the method and calculation by Goswami et al.[25] and Vaidya et al.[48] It is composed of a 340 mm x 340 mm x 70 mm metal plate. The size of the top is 560 x 580 mm<sup>2</sup>. The absorber tray is painted with black matte paint. It was made up of two glass plates. The back and sides of the cooker were insulated with Cerawool with a density of 64 kg/m<sup>3</sup> and heat conductivity of 0.48 W/m-K. The thickness of the Cerawool underneath the absorber plate is 50 mm. Cerawool has a thickness of 25 mm behind the sidewalls. As a result of this insulation, it can be considered as there is no or minimal leakage from the cooker. An Aluminum composite panel was used to house the solar cooker. Dimensions of Aluminium Composite Panel (ACP) are 500 x 500 mm<sup>2</sup>. T-type thermocouples that were calibrated were used to take temperature readings throughout the cooker at various points. The new cooker was built using the same methodology. The side walls are bent according to the angles optimized in the design. The surface is prepared by polishing, buffing, and chemical cleaning. Two float glasses (4 mm thickness) have been used with a spacing of 15 mm between the two glasses. Both inner and outer glass is fitted in a groove made in the frame by glue. Glass frame is hinged with the housing body.

### Experimental studies on new designed solar cooker

As developed and discussed earlier, a series of experiments have been conducted on a fully instrumented optimized solar cooker to measure its performance under load and no-load conditions. The actual cooking has also been undertaken in this cooker. The details of the experiments are given in Table 2.

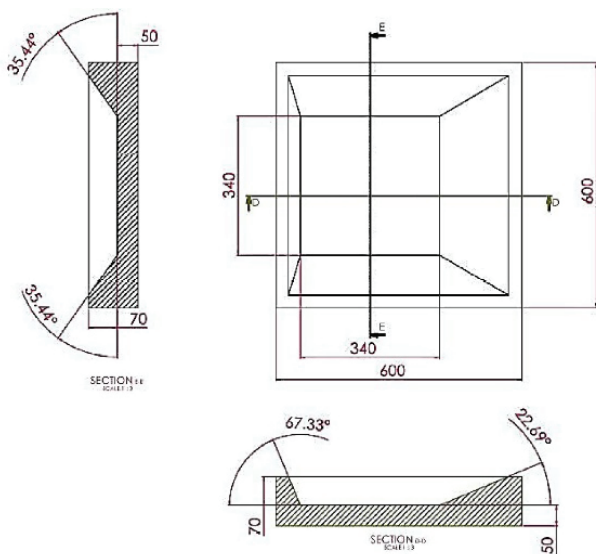

Figure 3. Dimensional details of new designed solar cooker.



Figure 4. Assembly drawing of new designed solar cooker.

**Table 2.** Details of experimentation

Sr. No	Date	Details
1	Day 1	No-load test. Cookers facing due south
2	Day 2	No-load test. Cookers facing due south
3	Day 3	Load test. Cookers facing due south
4	Day 4	Load test. Cookers facing due south
5	Day 5	Cooking test. Cookers facing due south

The newly developed solar cooker was placed through a thermal performance test to determine the figure of merit  $F_1$  for no-load situations and the figure of merit  $F_2$  for different loading conditions [22]. The first figure of merit represents efficiency level and is the proportion of optical efficiency to heat loss factor; it is assessed using a static test with no load and is termed the stagnation test.

$$F_1 = \frac{\eta_o}{U_{LS}} = \frac{T_u - T}{I_{GS}} \quad (7)$$

To determine the second figure of merit,  $F_2$ , the solar cooker is placed in the sun without a mirror but loaded fully with water and pots. The initial water is kept at 60 °C, the average between ambient and boiling temperatures. Temperature and sun radiation is recorded until the temperature achieves 95 °C.

The following equation is used to compute the second figure of merit,  $F_2$ .

$$F_2 = \frac{F_1 (MC)_w}{A(t_2 - t_1)} \times \ln \left\{ \frac{1 - \frac{1}{F_1} \left[ \frac{T_{w2} - T_a}{I_G} \right]}{1 - \left( \frac{1}{F_1} \right) \left[ \frac{T_{w1} - T_a}{I_G} \right]} \right\} \quad (8)$$

The value of  $I_G$  is averaged for all the values during the test period.

A cooking test is performed to evaluate the cooking capacity of the newly designed cooker in December, and the results are compared with the conventional cooker.

## RESULTS AND DISCUSSION

No-load tests, load tests, and cooking tests were carried out on the newly designed solar cooker. The results obtained during the tests are shown below:

Figure 5 depicts the variance in plate temperatures between the conventional and newly designed cookers and ambient temperature as a function of local time. Temperatures in both traditional and newly built cookers have been seen to rise with time. The hottest part of the day is between noon and 3:00 pm. Throughout the day, the temperature of the newly designed cooker is more than that of

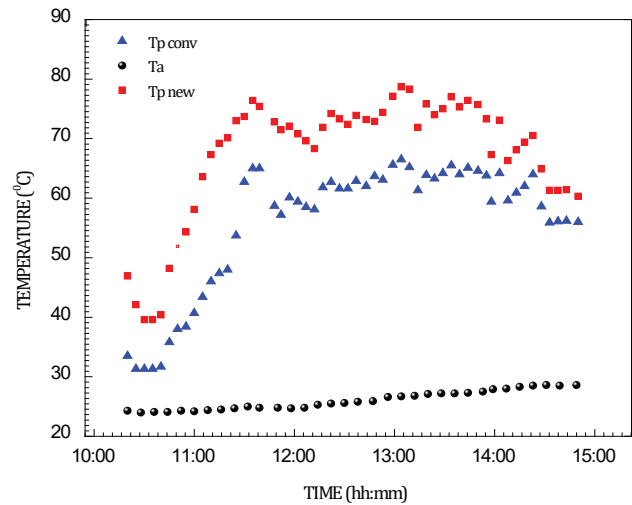
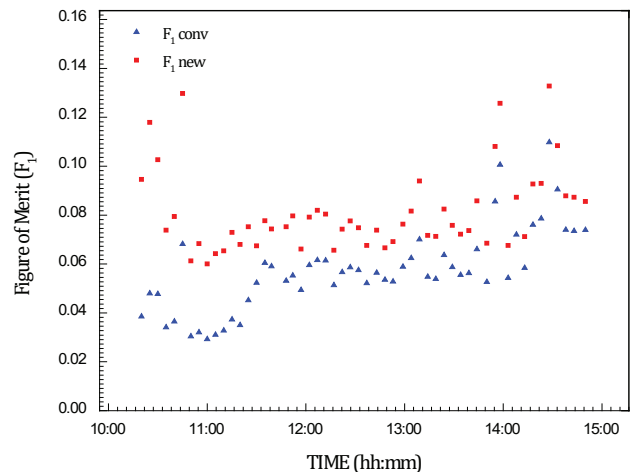

**Figure 5.** Variation of the temperature of Absorber plates of conventional and new designed solar cooker.

the conventional cooker. The highest temperature reached in the conventional cooker is 65 °C, while the highest temperature achieved in newly designed cooker is 76 °C. It is observed that the temperature of new designed solar cooker is about 16% higher from 11.30 am to about 2.00 pm.

Figure 6 and Figure 7 represent the variance of the figure of merit  $F_1$  of the conventional cooker and newly designed cooker with local time on day 1 and day 2. It is observed that the figure of merit  $F_1$  of the newly designed cooker is more throughout the day than that of the conventional cooker. The highest value is 0.11 and 0.07 for day 1 and day 2 for conventional cooker and 0.15 and 0.09 for newly designed cooker.

Figure 8 shows the temperature profile of air mass inside the conventional and newly designed cooker. The temperature obtained in the newly designed cooker is



**Figure 6.** Variation of Figure of merit  $F_1$  on day 1.

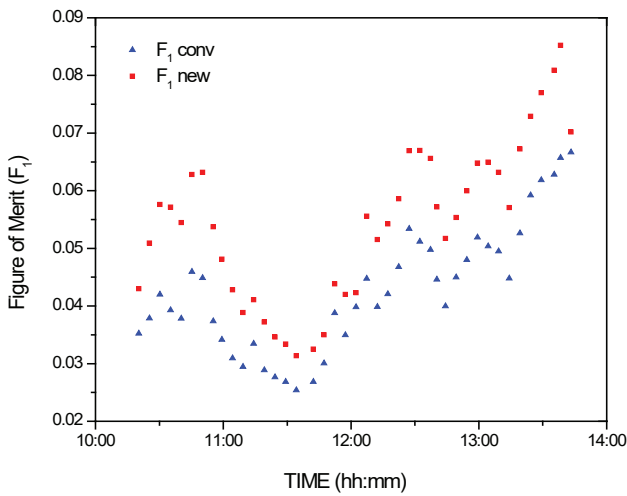

Figure 7. Variation of Figure of merit  $F_1$  on day 2.

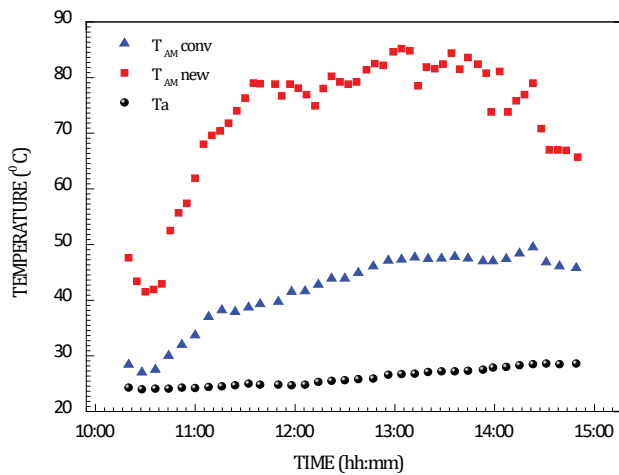

Figure 8. Temperature Profile of Air mass of Conventional and New Designed Cooker.

higher than the conventional cooker. This may be due to increased reflected beam radiation as an effect of optimized inclination of the sidewalls of the newly designed cooker. Max temperature of 86 °C is achieved in a newly designed cooker, and 49.5 °C is achieved in a conventional cooker. The average airmass temperature between 11:00 am and 2:00 pm is 43 °C, and that for the newly designed cooker is 78 °C.

Figure 9 shows the variation of pot temperatures of the conventional cooker and the newly designed cooker concerning time. The pot temperature of the newly designed cooker is found to be increasing earlier than the pot temperature of the conventional cooker. And it is found to be higher throughout the day. The highest temperature of the newly developed cooker is around 86 °C, while the highest temperature of the conventional cooker is around 60 °C.

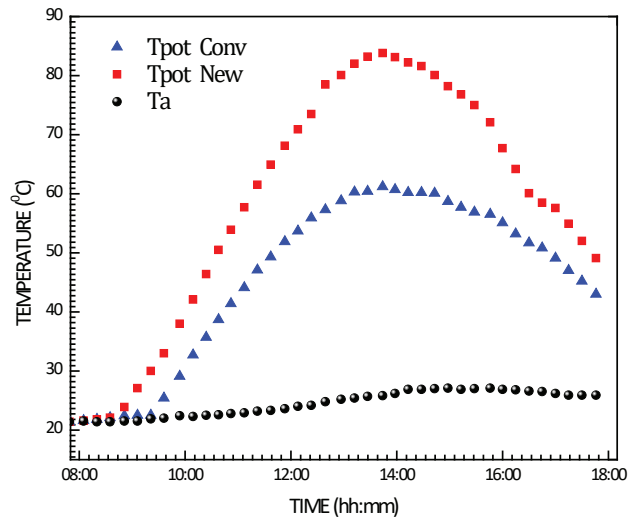

Figure 9. Variation of Pot Temperatures of Commercial Cooker and New Designed Solar Cooker.

The maximum value of Figure of merit  $F_1$  is calculated to be 0.15 for the newly developed cooker and 0.11 for the conventional cooker at 1.15 pm. The solar cooker having a Figure of merit  $F_1$  not less than 0.12 is graded as a grade A solar cooker, and  $F_1$  not less than 0.11 is graded as a Grade B solar cooker. The value of Figure of merit  $F_2$  is evaluated to be 0.59 for the newly designed cooker and 0.30 for the conventional cooker. It is to be noted that the accepted condition for the solar cooker to be qualified for the Indian Standards IS1 mark is that  $F_1$  must be larger than 0.11, and  $F_2$  must be greater than 0.40. In addition, if the value of  $F_1$  is 0.12 or greater, the solar cooker is categorized as “Grade A”; otherwise, it is labelled as “Grade B” [34].

A cooking test was also carried out with two pots of (200 gm rice+ 350 gm water) and two pots of (200 gm daal+ 350 gm water) in the newly designed cooker and the conventional cooker. Figure 10 shows the photographs of the daal



Figure 10. Daal and rice placed in commercial Solar cooker for cooking.

and rice placed in the conventional cooker before cooking, and Figure 11 shows the pictures of daal and rice in the newly designed cooker before cooking. After 130 minutes, the lentils were checked by pressing between the thumb and first finger to check if they were cooked through. The lentils in new designed solar cooker were found soft and



**Figure 11.** Daal and rice placed in new designed Solar Cooker for cooking.



**Figure 12.** Daal and rice placed in Commercial Solar Cooker after cooking period.



**Figure 13.** Daal and rice placed in New designed Solar cooker after cooking period.

disintegrated easily, but the lentils were found hard and did not disintegrate in the conventional cooker.

Figure 12 and Figure 13 show the photographs of daal and rice placed in the conventional Solar Cooker and newly designed Solar Cooker after the cooking test. Figure 14 and Figure 15 show the photographs of uncooked lentils from the conventional cooker, and fully cooked lentils from New designed Solar Cooker.



**Figure 14.** Uncooked Lentils from the conventional solar cooker.



**Figure 15.** Fully cooked Lentils from New designed Solar Cooker.

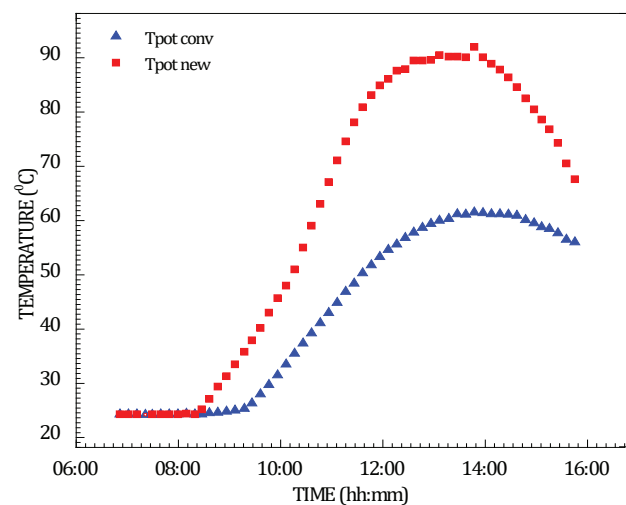

**Figure 16.** Graph of food temperature vs time for the real cooking tests.



The graph of food temperature in the newly designed cooker and that in the conventional cooker for the actual cooking tests is shown in Figure 16. It is observed that the temperature of the food in the newly designed solar cooker reaches the maximum value at about 90 °C at around 12.10 pm and remains at that temperature till 2.00 pm, during which the food gets cooked. The maximum temperature in the conventional cooker is 60 °C which is, between 1:00 pm to 3:00 pm, and the food is found uncooked.

## CONCLUSION

Design and development of box-type solar cooker with optimally reflecting side walls are carried out which can prepare the food for four persons even in December when the solar intensity is lowest. Experiments are conducted for thermal performance parameters at no-load conditions, load conditions, and cooking tests of solar cookers. Comparison between the newly designed cooker and the conventional cooker is carried out by performance. The optimized sidewall angles due south, due north, due east, and due west are calculated as 67.3°, 22.69°, 35.44°, and 35.44°, respectively. The side walls are made reflective with reflecting Aluminium sheets. The results show that the maximum plate temperature, the figure of merit  $F_1$ , and the maximum pot temperature of the newly developed solar cooker with optimally reflecting sidewalls during load test are higher than that of a conventional cooker. The maximum plate temperature is found to be 76 °C and 65 °C, respectively, in newly designed and conventional solar cookers during no-load tests. Temperatures are about 16% higher between 11:30 am and 2:00 pm in the newly designed cooker compared to the regular cooker. The maximum value of Figure of merit  $F_1$  is found to be 0.15 and 0.11 in newly designed and conventional solar cookers. The maximum value of Figure of merit  $F_2$  is found to be 0.59 and 0.30 in newly designed and conventional solar cookers. Thus, the newly designed cooker can be considered under the Grade A category. During load testing, the highest value of pot temperature for newly designed and conventional solar cookers is 86 °C and 60 °C, respectively, which is about 43% higher for the newly designed cooker. The highest cooking temperature in the newly designed cooker was maintained at 90 °C for almost two hours, whereas in the conventional cooker it was maintained at 60 °C for approximately two hours. Cooking tests depict that the food can be cooked in the newly designed cooker even at the lowest solar intensity in December, while the food was found uncooked in the conventional cooker.

Consequently, based on the experimental results, this cooker is predicted to be more efficient than the conventional cooker. In addition, future development may include modifying the design to make the solar cooker lighter so that it is easier to handle. Incorporating a few phase change materials may also increase heat retention while cooking.

## NOMENCLATURE

$A$	Aperture area of the cooker of the cover plate (m <sup>2</sup> )
$F_1$	The figure of Merit 1 from the stagnation test
$F_2$	The figure of Merit 2 from the load test
$I_{bn}$	Hourly direct normal beam radiation on a horizontal surface
$I_{GS}$	Insolation on the horizontal surface when the stagnation temperature is reached (W/m <sup>2</sup> )
$t_2-t_1$	Time taken for heating from $T_{w_1}$ to $T_{w_2}$ (s).
$T_a$	Ambient temperature (°C)
$T_{AM}^{conv}$	Temperature of air mass in the conventional solar cooker (°C)
$T_{AM}^{new}$	Temperature of air mass in new designed solar cooker (°C)
$T_C^{conv}$	Temperature of cover in the conventional solar cooker (°C)
$T_C^{new}$	Temperature of cover in new designed solar cooker (°C)
$T_P^{max Conv}$	Maximum plate temperature for conventional solar cooker. (°C)
$T_P^{max new}$	Maximum plate temperature for new designed solar cooker. (°C)
$T_{pot}^{Conv}$	Temperature of air mass in the conventional solar cooker (°C)
$T_{pot}^{new}$	Temperature of air mass in new designed solar cooker (°C)
$T_{ps}$	Stagnation plate temperature (°C)
Greek Letters	
$q$	Angle of Incidence
$d$	Declination angle
$w$	Hour angle
$j$	Latitude of a location
$g$	Solar Azimuth angle
$b$	The tilt angle of the surface with respect to the horizontal surface
$\eta_o$	Optical efficiency

## Abbreviations

$ACP$	Aluminum composite Panel
-------	--------------------------

## AUTHORSHIP CONTRIBUTIONS

Authors equally contributed to this work.

## DATA AVAILABILITY STATEMENT

The authors confirm that the data that supports the findings of this study are available within the article. Raw data that support the finding of this study are available from the corresponding author, upon reasonable request.

## CONFLICT OF INTEREST

The author declared no potential conflicts of interest with respect to the research, authorship, and/or publication of this article.

## ETHICS

There are no ethical issues with the publication of this manuscript.

## REFERENCES

- [1] Taner T, Dalkilic AS. A feasibility study of solar energy-techno economic analysis from Aksaray city, Turkey. *J Therm Eng* 2019;5:25–30. [\[CrossRef\]](#)
- [2] Pohekar SD, Ramachandran M. Utility assessment of parabolic solar cooker as a domestic cooking device in India. *Renew Energy* 2006;31:1827–1838. [\[CrossRef\]](#)
- [3] Farooqui SZ. A review of vacuum tube based solar cookers with the experimental determination of energy and exergy efficiencies of a single vacuum tube based prototype. *Renew Sustain Energy Rev* 2014;31:439–445. [\[CrossRef\]](#)
- [4] Sansaniwal SK, Sharma V, Mathur J. Energy and exergy analyses of various typical solar energy applications: A comprehensive review. *Renew Sustain Energy Rev* 2018;82:1576–1601. [\[CrossRef\]](#)
- [5] Abou-Ziyan HZ. Experimental investigation of tracking paraboloid and box solar cookers under Egyptian environment. *Appl Therm Eng* 1998;18:1375–1394. [\[CrossRef\]](#)
- [6] Yettou F, Gama A, Panwar NL, Azoui B, Malek A. Receiver temperature maps of parabolic collector used for solar food cooking application in Algeria. *J Therm Eng* 2018;4:1656–1667. [\[CrossRef\]](#)
- [7] Algifri AH, Al-Towaie HA. Efficient orientation impacts of box-type solar cooker on the cooker performance. *Sol Energy* 2001;70:165–170. [\[CrossRef\]](#)
- [8] Aramesh M, Ghalebani M, Kasaeian A, Zamani H, Lorenzini G, Mahian O, et al. A review of recent advances in solar cooking technology. *Renew Energy* 2019;140:419–435. [\[CrossRef\]](#)
- [9] Omara AAM, Abuelnuor AAA, Mohammed HA, Habibi D, Younis O. Improving solar cooker performance using phase change materials: A comprehensive review. *Sol Energy* 2020;207:539–563. [\[CrossRef\]](#)
- [10] Khatri R, Goyal R, Sharma RK. Advances in the developments of solar cooker for sustainable development: A comprehensive review. *Renew Sustain Energy Rev* 2021;145:111166. [\[CrossRef\]](#)
- [11] Sawarn H, Kumar Shukla S, Singh Rathore PK. Development in solar cooking technology in the last decade: A comprehensive review. *International Conference on Futuristic and Sustainable Aspects in Engineering and Technology (FSAET 2020)*; 2020 Dec 18-19; Bristol: IOP Publishing; 2021. Article 012046. [\[CrossRef\]](#)
- [12] Kumar AR, Ramakrishnan M. A scoping review on recent advancements in domestic applications of solar thermal systems. *J Therm Eng* 2022;8:426–444. [\[CrossRef\]](#)
- [13] NKhonjera L, Kuboth M, König-Haagen A, John G, King'ondeu C, Brüggemann D, et al. Experimental investigation of a finned pentaerythritol-based heat storage unit for solar cooking at 150–200 °C. *Energy Procedia* 2016;93:160–167. [\[CrossRef\]](#)
- [14] Panchal H, Patel J, Chaudhary S. A comprehensive review of solar cooker with sensible and latent heat storage materials. *Int J Ambient Energy* 2019;40:329–334. [\[CrossRef\]](#)
- [15] Arunachala UC, Kundapur A. Cost-effective solar cookers: A global review. *Solar Energy* 2020;207:903–916. [\[CrossRef\]](#)
- [16] Komolafe CA, Okonkwo CE. Design, fabrication, and thermal evaluation of a solar cooking system integrated with tracking device and sensible heat storage materials. *Front Energy Res* 2022;10:1–13. [\[CrossRef\]](#)
- [17] Asrori A, Suparman S, Wahyudi S, Widhiyanuriyawan D. An experimental study of solar cooker performance with thermal concentrator system by spot fresnel lens. *East Eur J Enterp Technol* 2020;5:31–41. [\[CrossRef\]](#)
- [18] Cuce PM, Kolayli S, Cuce E. Enhanced performance figures of solar cookers through latent heat storage and low-cost booster reflectors. *Int J Low Carbon Technol* 2020;15:427–433. [\[CrossRef\]](#)
- [19] Milikias E, Bekele A, Venkatachalam C. Performance investigation of improved box-type solar cooker with sensible thermal energy storage. *Int J Sustain Eng* 2021;14:507–516. [\[CrossRef\]](#)
- [20] Mehta S, Channiwal SA. Comparative study of solar cookers. *Solar Energy Society of India*. New Delhi: Tata McGraw Hill; 1988. p. 118–124.
- [21] Channiwal SA, Doshi NI. Heat loss coefficients for box-type solar cookers. *Sol Energy* 1989;42:495–501. [\[CrossRef\]](#)
- [22] Mullick SC, Kandpal TC, Kumar S. Testing of box-type solar cooker: second figure of merit F2 and its variation with load and number of pots. *Sol Energy* 1996;57:409–413. [\[CrossRef\]](#)
- [23] Gawande VB, Dhoble AS, Zodpe DB. Effect of roughness geometries on heat transfer enhancement in solar thermal systems--a review. *Renew Sustain Energy Rev* 2014;32:347–378. [\[CrossRef\]](#)
- [24] Kumar S. Natural convective heat transfer in trapezoidal enclosure of box-type solar cooker. *Renew Energy* 2004;29:211–222. [\[CrossRef\]](#)
- [25] Goswami V, Harijan H, Pargi S, Pal SC, Vaidya H, Channiwal SA. Analysis, design and performance evaluation of a light weight, energy efficient solar cooker. *International Conference on Energy, Environment and Economics, Edinburgh, United Kingdom, September 2016, vol.3, World Energy and Environment Technology Ltd.*; p. 120–125.
- [26] Harmim A, Merzouk M, Boukar M, Amar M. Performance study of a box-type solar cooker employing an asymmetric compound parabolic concentrator. *Energy* 2012;47:471–480. [\[CrossRef\]](#)

- [27] Pejack ER. Mathematical model of the thermal performance of box-type solar cookers. *Renew Energy* 1991;1:609–615. [\[CrossRef\]](#)
- [28] Terres H, Lizardi A, López R, Vaca M, Chávez S. Mathematical model to study solar cookers box-type with internal reflectors. *Energy Procedia* 2014;57:1583–1592. [\[CrossRef\]](#)
- [29] Funk PA, Larson DL. Parametric model of solar cooker performance. *Sol Energy* 1998;62:63–68. [\[CrossRef\]](#)
- [30] Hajibeigy MT, Walvekar R, Aravind CV. Mathematical modelling, simulation analysis of a photovoltaic thermal system. *J Therm Eng* 2021;7:291–306. [\[CrossRef\]](#)
- [31] Vaidya HA, Channiwala SA. Mathematical modeling of a box type solar cooker incorporating contact resistance. *J Sci Ind Res* 2022;81:922–931. [\[CrossRef\]](#)
- [32] Das TCT, Karmakar S, Rao DP. Solar box-cooker: Part I-modeling. *Sol Energy* 1994;52:265–272. [\[CrossRef\]](#)
- [33] El-Sebaai AA, Domański R, Jaworski M. Experimental and theoretical investigation of a box-type solar cooker with multi-step inner reflectors. *Energy* 1994;19:1011–1021. [\[CrossRef\]](#)
- [34] Kahsay MB, Paintin J, Mustafa A, Haileselassie A, Tesfay M, Gebray B. Theoretical and experimental comparison of box solar cookers with and without internal reflector. *Energy Procedia* 2014;57:1613–1622. [\[CrossRef\]](#)
- [35] Kumar N, Chavda T, Mistry HN. A truncated pyramid non-tracking type multipurpose domestic solar cooker/hot water system. *Appl Energy* 2010;87:471–477. [\[CrossRef\]](#)
- [36] Kurt H, Deniz E, Recebli Z. An investigation into the effects of box geometries on the thermal performance of solar cookers. *Int J Green Energy* 2008;5:508–519. [\[CrossRef\]](#)
- [37] Zamani H, Mahian O, Rashidi I, Lorenzini G, Wongwises S. Exergy optimization of a double-exposure solar cooker by response surface method. *J Therm Sci Eng Appl* 2017;9:011003. [\[CrossRef\]](#)
- [38] Farooqui SZ. Angular optimization of dual booster mirror solar cookers - Tracking free experiments with three different aspect ratios. *Sol Energy* 2015;114:337–348. [\[CrossRef\]](#)
- [39] Sethi VP, Pal DS, Sumathy K. Performance evaluation and solar radiation capture of optimally inclined box type solar cooker with parallelepiped cooking vessel design. *Energy Convers Manag* 2014;81:231–241. [\[CrossRef\]](#)
- [40] Mahavar S, Rajawat P, Punia RC, Sengar N, Dashora P. Evaluating the optimum load range for box-type solar cookers. *Renew Energy* 2015;74:187–194. [\[CrossRef\]](#)
- [41] Shaik S, Bhardwaj M, Agarwal S, Yendaluru RS, Hasanuzzaman M, Sharma K V. Evaluation of optical transmissivity of transparent materials on the performance of solar flat plate collectors. *J Sol Energy Eng* 2021;143:054501. [\[CrossRef\]](#)
- [42] Zafar HA, Khan MY, Badar AW, Tariq R, Butt FS. Introducing a novel design in the realm of box type solar cookers: An experimental study. *J Renew Sustain Energy* 2018;10:043707. [\[CrossRef\]](#)
- [43] Guidara Z, Souissi M, Morgenstern A, Maalej A. Thermal performance of a solar box cooker with outer reflectors: Numerical study and experimental investigation. *Sol Energy* 2017;158:347–359. [\[CrossRef\]](#)
- [44] Coccia G, Di Nicola G, Pierantozzi M, Tomassetti S, Aquilanti A. Design, manufacturing, and test of a high concentration ratio solar box cooker with multiple reflectors. *Sol Energy* 2017;155:781–792. [\[CrossRef\]](#)
- [45] Cuce E. Improving thermal power of a cylindrical solar cooker via novel micro/nano porous absorbers: A thermodynamic analysis with experimental validation. *Sol Energy* 2018;176:211–219. [\[CrossRef\]](#)
- [46] Amer EH. Theoretical and experimental assessment of a double exposure solar cooker. *Energy Convers Manag* 2003;44:2651–2663. [\[CrossRef\]](#)
- [47] Sudhanshu D. *Solar Radiation Hand Book*. Solar Energy Centre, MNRE Indian Metrological Department; 2008.
- [48] Vaidya H, Channiwala S, Rathod M. Quality assessment of box - Type solar cooker using aluminium composite panel. *Res Appl Therm Eng* 2022;5:1–10.
- [49] Sukhatme SP, Nayak JK. *Solar energy*. 4th ed. New York: McGraw-Hill Education; 2017.