



Research Article

Investigation of friction characteristics of control cables

Cüneyt BAYRAM*^{ORCID}, Zeynep PARLAR^{ORCID}

Department of Mechanical Engineering, Istanbul Technical University, Istanbul, Türkiye

ARTICLE INFO

Article history

Received: 12 January 2021

Accepted: 14 June 2021

Key words:

Control Cables; Friction;
Lubrication; Push and Pull
Cables

ABSTRACT

This study aims to minimize the friction forces in order to obtain the best feel and minimum effort in the command and control cable part of the shift systems. For this purpose, lubricant, amount of lubricant and application method were investigated. Theoretical and experimental approaches are discussed by examining the studies on this subject. In the presented study, friction measurements were taken in the laboratory environment by applying different amounts of lubrication on the wire exposed to friction, and the amount of lubrication required for minimum effort was determined experimentally. It was observed that the friction force was decreased about 60% with oil running compared to dry running. Studies show that friction forces increase in excessive lubrication as well as in cases where there is no lubrication and little lubrication. The optimum amount of oil was obtained to be 0.1 g. It has developed guidelines for determining the friction factor for those who design shift cable and control cable used in different areas.

Cite this article as: Bayram C, Parlar Z. Investigation of friction characteristics of control cables. Sigma J Eng Nat Sci 2022;40(3):507–512.

INTRODUCTION

New research focuses on issues such as increasing vehicle driving comfort, improving NVH values, and improving user feel. When we consider the components, we use the most as a driver, one of the leading ones is undoubtedly the gear shift mechanism. System that provides gear change in vehicles; It consists of a mechanism called shifter that provides forward-backward and left-right movements under the gear lever and cables that transmit these movements to the transmission. The cables generally consist of the inner cable, the protective sheath defined as conduit, the fasteners connecting the transmission and the shifter and the grommet.

Control cable is a type of flexible cable used to transmit mechanical force or motion with an inner cable movement in association with a conduit. Figure 1 shows the schematic view of the inner cable and conduit pair. Generally, it consists of inner cable providing movement, teflon tube as sheath to reduce friction, protective sheath defined as conduit that protects these two from external impacts and corrosion, fasteners connecting the inner cable with the mechanism and grommets that enable positioning between the interior and exterior of the vehicle. It is generally used in bicycle, motorcycle and automobile brake and gear systems. Recently, researchers who are doing robotic research and designing medical devices have included motion cables in robot applications [1, 2].

*Corresponding author.

*E-mail address: bayramc@itu.edu.tr

This paper was recommended for publication in revised form by Regional Editor Amin Shahsavari.



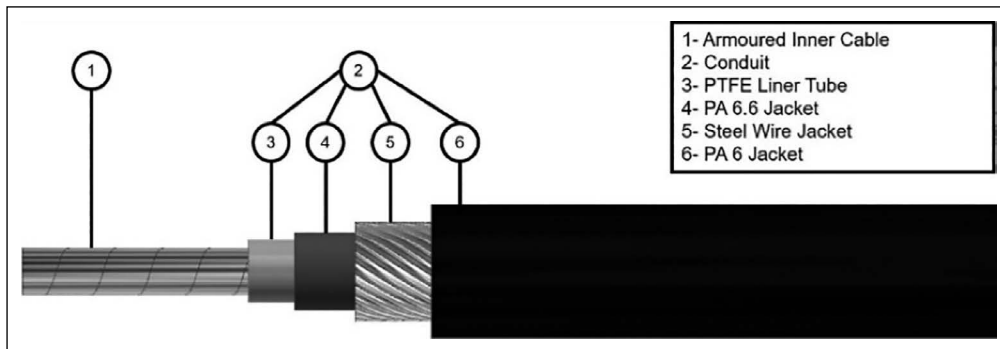

Figure 1. Elements of control cable.

In this system, the part that has the maximum effect on the feel and comfort of the driver is the control cables. Gear shift quality is an extremely important indicator of comfort in manual transmission vehicles. Shift quality can be broadly divided into four main categories: shift effort, exactness, NVH and shift comfort [1]. To increase shift quality and comfort for the end user, control cables must be able to transmit movements with minimum effort.

Researches have been made on the comfort expectations of vehicle drivers and the subtitles of gear shifting quality have been examined to meet these expectations. New design suggestions have been made [2]. Previously, the effects of shifting feel for different combinations of the cable route have been studied. By creating different mathematical models and comparing the friction simulations of these models, it was aimed to determine the appropriate cable route [1]. Again, among the studies conducted, the behaviour of vehicle control cables of surfaces exposed to friction against different coating materials were compared and the results were presented [3].

In the presented study, the effects of lubrication, lubricant type and amount of lubricant in order to reduce friction values in order to provide maximum comfort and best feeling in gear cables were evaluated.

In control cables, the shifting force is created by the inertia of the inner cable during movement and the friction force between the inner cable and the protective sheath. Here, the interventionable part is the friction between the inner cable and the conduit. This system will be examined as a tribological structure.

Due to the contact between the inner cable and the conduit, lubrication is made in this area. Lubrication minimizes the wear of these structures in contact with each other and increases the life of these structures by protecting them from corrosive effects. To achieve this, grease oils have been used for many years. However, this type of high viscosity semi-solid lubricants create high friction with their retention effect. In Gene C. Weitz's work, it is seen that different lubricant types work on friction behaviour. In the study, it was concluded that liquid lubricants give more successful friction results compared

Table 1. Main parameters of lubricant [6]

Main parameters of lubricants	
Specific gravity ta 25 °C (77 °F)	0.970
Viscosity, kinematic at 25 °C (mm ² /s)	500
Surface tension at 25 °C (N/m)	0.022

to semi-solid lubricants in systems under kinetic friction and it supports this study [4].

In this study, besides corrosive protection and wear protection, a lubrication in which high friction values are reduced will be studied. For this, low viscosity liquid lubricant will be used instead of grease lubricant. At the same time, the optimum application amount of this oil will be determined. Thus, the targeted maximum friction force of 2 N will be reached, and shift quality and comfort will be brought to the best levels.

MATERIAL AND METHODS

Lubrication

The amount of lubricant applied to the control cable under mass production conditions is 0.3 g. Although this amount is not worth the result of a certain study, it is a value determined by experience. In this study, samples were prepared for the values before and after this value applied under serial conditions. Four different amounts of oil were applied in the experiment and a dry-prepared control cable was used. Control cable treated with 0.05 g, 0.1 g, 0.3 g and 0.5 g oil was prepared as test samples. It is possible to see different lubricant applications in motion cables. Commonly used grease lubricants. The effects of different types of lubricants were investigated in previous studies [5]. These studies show that liquid type lubricants have a lower maximum traction coefficient than grease lubricants. Liquid silicone oil was preferred as it was worked with the aim of decreasing friction forces. Silicone oil with a viscosity of 500 mm²/s at 25 °C was used as a lubricant [6]. Main parameters of the lubricant are shown in Table 1.

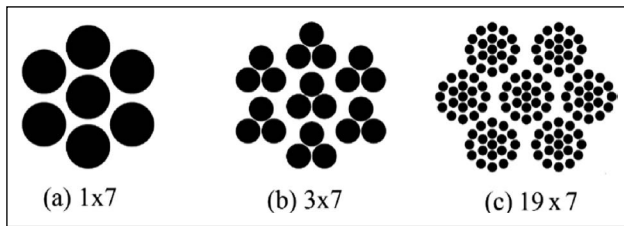

Figure 2. Inner cable winding forms used in the control cables [7].

Table 2. Main parameters of inner cable

Main parameters of cable	
Inner cable radius (m)	0.0016
Conduit radius (m)	0.00175
Inner cable length (m)	1.233
Velocity (m/s)	0.015

Inner Cable and Conduit

Many inner cable and conduit options are available for control cables. Correct selection of inner cable and conduit is extremely important for control cable applications. Inner cables and conduits are determined according to the main criteria of hardness, material and diameter size. Generally, the diameter of the inner cables and conduits affect the load and size requirement. There are studies conducted with inner cables with many different constructions and the main ones of these, 1x7, 7x3 and 7x19 construction, are shown in Figure 2 [7].

The structure of the inner cable used in the control cable is important in determining the curvature radius and buckling effect. Each fiber in a 1x7 coiled inner cable of the same diameter is thicker and more resistant to buckling, while the 19x7 coiled inner cable will be more flexible because it contains thinner fibers. However, in recent times, customer demands, especially commercial vehicles, require internal cable designs to meet higher pressure and pull forces. In line with this request, a cable type of 1x19 structure, which has a schematic representation in Figure 3 (a), has been developed. This new type of inner cable winding brings some handicaps with it. While this inner cable type provides higher compression and pulling forces, it is exposed to buckling effect. In order to prevent buckling effects, the top of the 1x19 winding cable is covered with an armoured structure. Thus, while the buckling effect is eliminated, the friction effects caused by the indented surface in plain winding are also reduced. For this reason, the use of 1x19 coiled armoured inner cable has been considered in the presented study. Generally, application factors such as the applied load and volume limits affect the inner cable and conduit diameter. Since the thickness of the cable does not cause a problem related to the volume, $\varnothing 3.2$ mm inner cable diameter 1233 mm straight inner cable length is preferred. Main parameters of the inner cable are shown in Table 2.

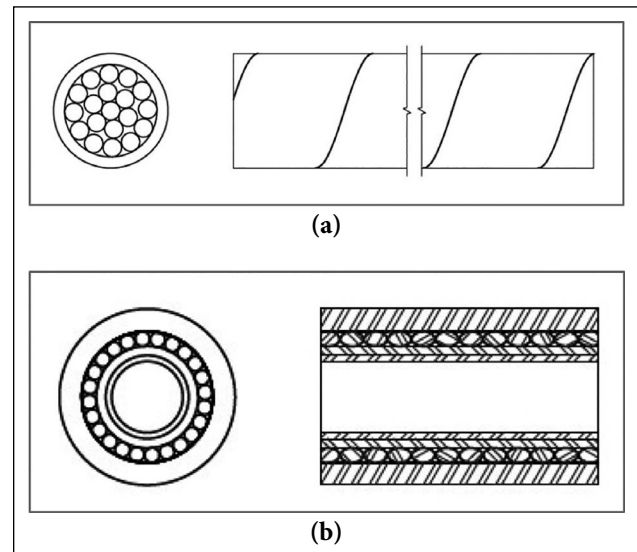

Figure 3. Sketch of inner cable and conduit; (a) 1x19 coiled armoured inner cable (b) PTFE coated, steel braided and PVC coated conduit.

The most important factor affecting sheath material selection is friction. In the studies, minimum friction coefficient and minimum friction force between steel inner cable and sheath were obtained with PTFE material [7]. Stainless steel inner cable material and in order to reduce friction, PTFE coated, steel braided and PVC coated conduit has been selected.

Two conduits with the same inner diameter will have a higher resistance to buckling with more wall thickness. However, since the cross-sectional area is larger, its resistance to elongation will be higher. Accordingly, cable sheath with an inner diameter of $\varnothing 3.5$ mm is used. The schematic view of the conduit is given in Figure 3b.

THE EXPERIMENTAL SETUP AND PARAMETERS

The experiment setup shown in Figure 4 was used in the study. The experimental setup works by connecting a load cell and a linear ruler to the apparatus on which the fitting is attached and the principle that a robocylinder moves this apparatus. As the robocylinder moves along the length to be measured, it reads the load cell friction values, and the linear ruler controls the stroke during the measurement. Tested motion cables will be moved along +25 mm stroke from the nominal position at a constant speed of 15 mm/s by connecting the other end to the robocylinder, with one end free. It will then be moved from +25 mm to -25 mm. Finally, by moving it from -25 mm to its nominal position, friction values in the push and pull directions of the total 50 mm stroke are obtained in N. The stroke value is determined by the technical picture of the product we test. The linear ruler that we control the stroke has a measurement accuracy of $\pm 0.02\%$. Friction measurements were measured with the

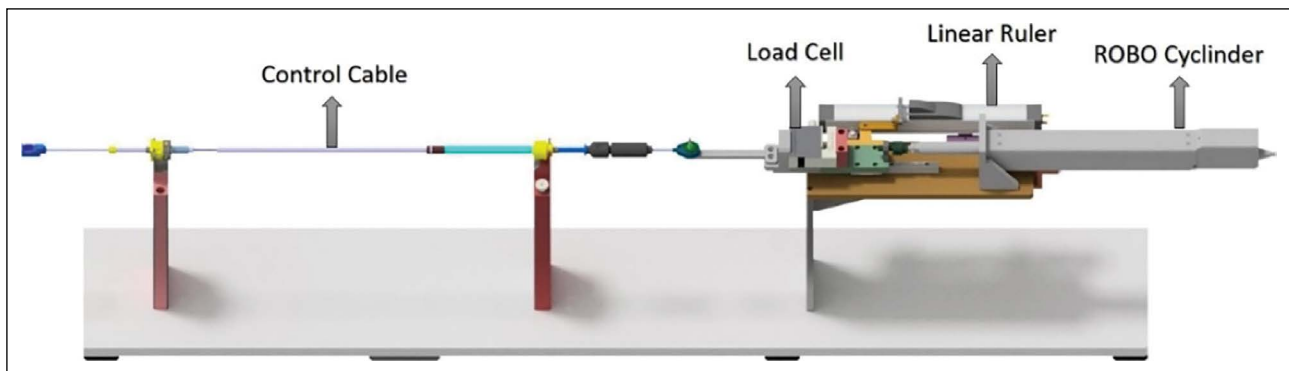

Figure 4. The experimental setup.

Load Cell with a capacity of 20 kg and C3 sensitivity according to OIML R60 norms, and the results were tabulated.

In the experiments, the control cable is positioned straight and the measurement is made. The results obtained in this way were evaluated. Thus, friction increases caused by bending do not affect our work. By eliminating the elements other than the lubricant, the friction effect of the amount of lubricant can be seen more clearly.

A spray gun is used to apply the oil on the inner cable. Before applying the lubricant, the weight of the inner cable is measured with a 0.001g precision scale. Two of these guns are placed opposite each other and while the guns are spraying, an inner cable is passed between them. The inner cable, on which lubricant has been applied in this way, is then put into the conduit and assembled. Silicone oil is fed into the spray gun with a pressure of 1.5 bar. Oil is pulverized with 1 bar of air fed to the spray gun. It is applied to the product with 4.5 bar air entering the spray gun with an independent supply. Oil is continuously applied to the inner cable surface that passes between these two guns at a speed of 1 m/s. The amount of oil to be applied is changed with the adjustment valve on the spray gun. After that, the amount of lubricant is compared with the weight of the unlubricated cable to obtain desired oil amount. Thus, lubricated cables with different amounts of oil are prepared.

RESULTS AND DISCUSSION

Dry tested to see the friction effect of the lubricant on the control cables. Then, the data of the experiments were collected by respectively applying 0.05 g, 0.1 g, 0.3 g and 0.5 g of oil on the inner cable. Five experiments were made for each case and the arithmetic averages of the obtained data were taken. The vertical axis of the graph shows the friction force in N and the horizontal axis shows the cable stroke in mm. Positive values in the graph show the data obtained during pulling, while negative values show the values obtained during pushing. Evaluation is calculated on absolute value. The graph of the friction test results of the dry control cable is given in Figure 5. It is seen that the friction force varies between 1.5 and 2.0 N.

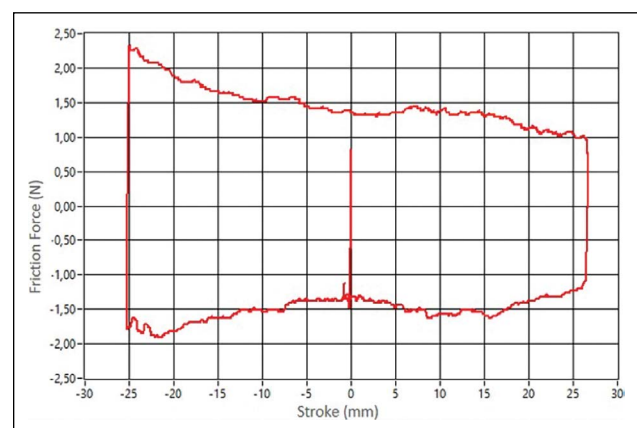

Figure 5. Results of friction tests of dry control cable.

Figure 6 shows the friction test results of the cables with 0.05 g, 0.1 g, 0.3 g and 0.5 g lubricant, respectively. In order to see the effect of the amount of lubricant, all properties of the cables were taken the same in the experiments. As expected, a lower friction force is observed compared to dry running. It has been observed that the friction force is around 1N. It can be said that approximately 60% reduction in friction force is achieved by using lubricant.

The graphic showing the relationship between the amount of lubricant and friction force created on the basis of the results is given in Figure 7. The average friction force values in Figures 5 and 6 are taken in the account. The horizontal axis shows the amount of lubricant in grams and the vertical axis shows the friction force in Newton. Each point on the graph shows the grammage on the horizontal axis versus the friction force on the vertical axis.

The results of the study showed that the optimum amount of oil was 0.1 g, and an average friction force of 1.1 N was observed in this case. As seen in Figure 7, although the increase in the amount of lubricant at a certain rate has an effect in reducing the friction forces in the system, it has an increasing effect on the friction after a certain value.

It is known that greases adhere well to metal surfaces. Since the mechanism examined in this study is a closed cycle, the oil does not need to adhere to the surface. In sci-

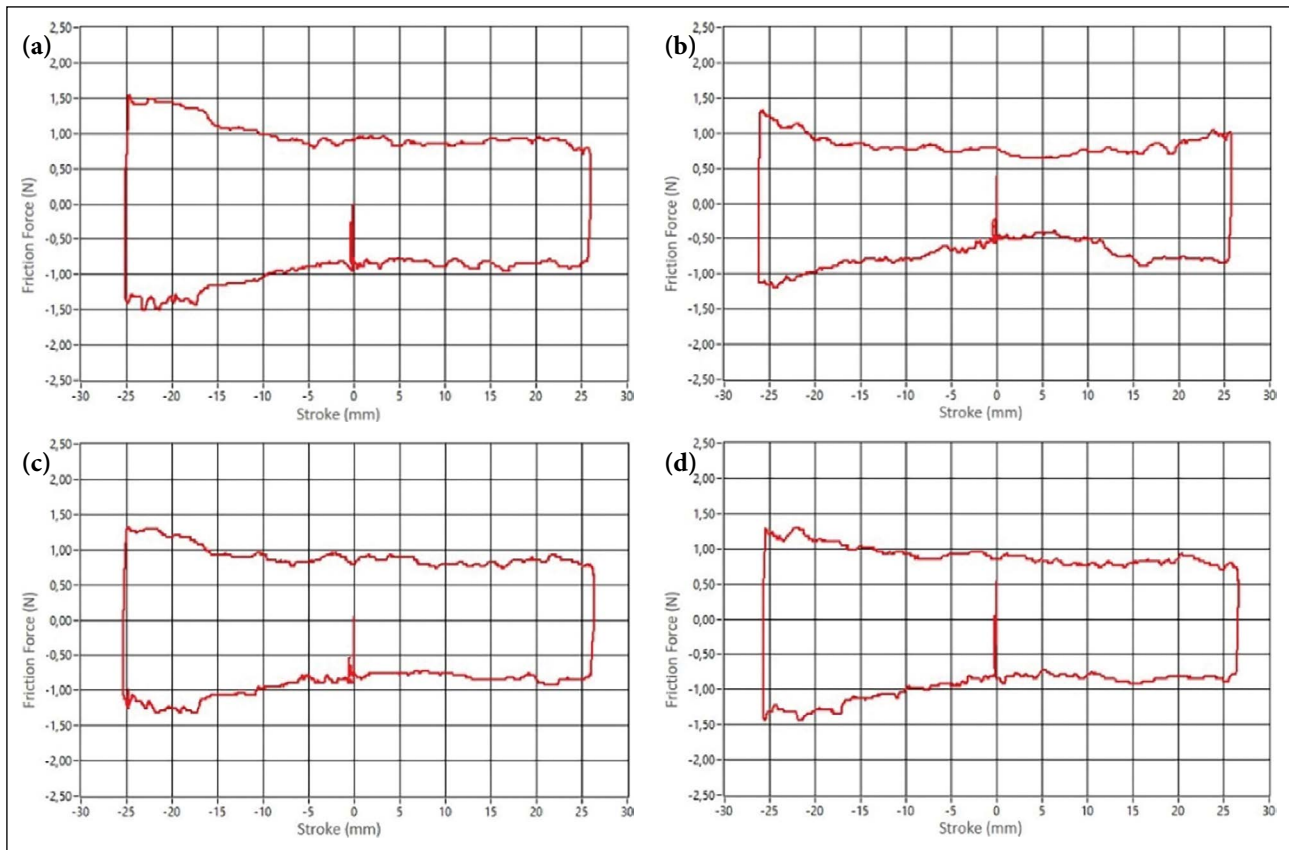

Figure 6. Results of friction tests under lubricated condition; (a) 0.05 g lubricant, (b) 0.1 g lubricant, (c) 0.3 g lubricant, (d) 0.5 g lubricant.

entific studies examining liquid lubricants, the friction behaviour of liquid lubricants on sliding metal surfaces under different cycle numbers has been revealed. These studies have shown that liquid lubricants give low friction coefficients under shear. This situation supports the results obtained from this study [8].

Mathematical models obtained from analytical studies used to calculate friction force in the literature; coincides with the results obtained in this study for both dry friction, oily friction and hydrodynamic friction [9, 10].

CONCLUSION

In this study, the effect of different amounts of lubricant applied to the inner cable of control cables on friction forces was investigated. It has been observed that the highest friction force occurs in the dry control cable. The frictional force varies from 1.5 to 2 N under this condition. It was observed that the friction force was decreased by increasing the amount of lubrication. A reduction in friction force of approximately 60% was achieved by lubrication. Also, after a certain value, as the amount of lubrication increased, the friction force increased. It was observed that the optimum amount of oil is 0.1 g and the friction force is obtained ap-

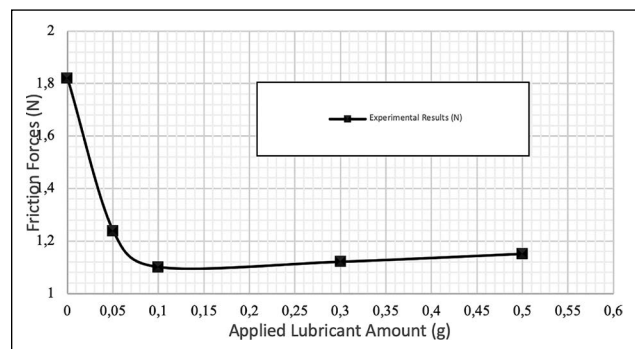

Figure 7. Oil amount-friction force relationship.

proximately 1.1 N for this conditions. Compared to grease lubricant, it has been shown in the literature that liquid lubricants give a lower coefficient of friction under sliding conditions. The results obtained in the presented study are in accordance with the literature in this sense. With the effect of different positioning, different lubricant types, different coupling of inner cable and protective sheath materials on control cables on friction forces, wider studies can be done. Studies of control cables used in the automotive industry can be evaluated based on different products with similar construction and in different sectors.

ACKNOWLEDGMENTS

The authors also wish to express their gratitude towards Ficoso International for providing the support in this work.

AUTHORSHIP CONTRIBUTIONS

Authors equally contributed to this work.

DATA AVAILABILITY STATEMENT

The published publication includes all graphics and data collected or developed during the study.

CONFLICT OF INTEREST

The author declared no potential conflicts of interest with respect to the research, authorship, and/or publication of this article.

ETHICS

There are no ethical issues with the publication of this manuscript.

REFERENCES

- [1] Deleener J, Sekitou A, Ohta, M. Development of a cable model for virtual shift feeling evaluation. SAE Technical Paper 2015-01-2332, 2015. [\[CrossRef\]](#)
- [2] Sporleder J, Mohlin M, Olsson M. Development of shift comfort for manual transmissions in passenger cars. ATZ 06/2008. [\[CrossRef\]](#)
- [3] Carlson LE, Bradley DV, Frey DD. Efficiency of prosthetic cable and housing. J Prosthet Orthot 1995;7:96–99. [\[CrossRef\]](#)
- [4] Weitz GC. Coefficient of friction measurement between cable and conduit surfaces under varying normal loads. IEEE Trans Power Appar Syst 1985;PAS-104:16–21. [\[CrossRef\]](#)
- [5] Yamanaka M, Kumagai K, Inoue K, Hata H. Evaluation of property difference between traction oil and traction grease. J Adv Mech Design Syst Manuf 2009;3:366–377. [\[CrossRef\]](#)
- [6] Form No. 95-516-01 E, Trademark of The Dow Chemical Company (“Dow”) or an affiliated company of Dow XIAMETER™ PMX-200 Silicone Fluid, 50–1,000 cSt, The Dow Chemical Company, 2017.
- [7] Chen D, Yun Y, Deshpande AD. Experimental Characterization of Bowden Cable Friction, 2014 IEEE International Conference on Robotics & Automation (ICRA) Hong Kong Convention and Exhibition Center May 31 - June 7, 2014. [\[CrossRef\]](#)
- [8] Jiajia J, Guangbin Y, Chunli Z, Shengmao Z, Yujuan Z, Pingyu Z. Effects of magnetic ionic liquid as a lubricant on the friction and wear behavior of a steel-steel sliding contact under elevated temperatures. Friction 2021;9:61–74. [\[CrossRef\]](#)
- [9] Chen G. Handbook of Friction-Vibration Interactions. Cambridge: Woodhead Publishing, 2014.
- [10] Robinson JW, Zhou Y, Bhattacharya P, Erck R, Qu J, Timothy J. Probing the molecular design of hyper-branched aryl polyesters towards lubricant applications. Sci Rep 2016;6:1–10. [\[CrossRef\]](#)