

This paper was recommended for publication in revised form by Regional Editor Bekir Sami Yilbaş

GEOTHERMAL ENERGY USE IN HYDROGEN PRODUCTION

***Mehmet Kanoglu**

Department of Mechanical Engineering,
 University of Gaziantep, 27310 Gaziantep, Turkey

Ceyhun Yilmaz

Department of Mechanical Engineering,
 University of Gaziantep, 27310 Gaziantep, Turkey

Aysegul Abusoglu

Department of Mechanical
 Engineering,
 University of Gaziantep, 27310
 Gaziantep, Turkey

Keywords: Hydrogen, geothermal energy, hydrogen production, hydrogen liquefaction

** Corresponding author: Phone: +903172508, Fax: +903423601104*

E-mail address: kanoglu@gantep.edu.tr

ABSTRACT

We propose the use of geothermal energy for hydrogen production and liquefaction, and investigate six possible models for accomplishing such a task. The models are studied thermodynamically in order to assess their performance for maximizing hydrogen production rate while minimizing the used geothermal energy. The effect of geothermal water temperature on various thermodynamic performance of the models is investigated. The models include using geothermal work output as the work input for an electrolysis process (Model 1); using part of geothermal heat to produce work for electrolysis process and part of geothermal heat in an electrolysis process to preheat the electrolysis water (Model 2); using geothermal heat in an absorption refrigeration process to precool the gas before the gas is liquefied in a liquefaction cycle (Model 3); using part of the geothermal heat for absorption refrigeration to precool the hydrogen gas and part of the geothermal heat to produce work with a binary geothermal cycle and use it in a liquefaction cycle (Model 4); using geothermal work output as the electricity input for a liquefaction cycle (Model 5); and using part of geothermal work for electrolysis and the remaining part for liquefaction (Model 6).

INTRODUCTION

Hydrogen, an alternative energy source, is subject of a lot of research work and some consider it as the energy of the future [1]. The total cost of producing hydrogen depends on production, liquefaction, storage, and distribution costs [2]. Today approximately 9 billion kilograms of hydrogen are produced annually. More than 95% of the merchant hydrogen is used for industrial applications in the chemical, metals, electronics, and space industries.

Hydrogen provides the connecting point between renewable electricity production and transportation, stationary and portable energy needs. When the electricity from solar photovoltaic, wind, geothermal, ocean and hydro technologies is used to produce and store hydrogen, the renewable source becomes more valuable and can meet a variety of needs. In transportation applications, hydrogen provides a way to convert renewable resources to fuel for vehicles [3].

If hydrogen is to become the energy of the future, it must be produced using renewable energy sources and the technical and economic problems on its production, storage, transportation, and use should be solved. There are various methods used in hydrogen production. Some of these methods include steam methane reforming, electrolysis, coal gasification, liquid

reforming, high-temperature electrolysis, high-temperature thermo-chemical water-splitting, photo-biological, and photo-electrochemical. The first three methods are currently used while the remaining ones are still being researched or developed. These methods may require electricity and/or heat inputs [4]. A number of existing and planned demonstration projects use electrolysis, even though it is one of the more energy intensive processes for producing hydrogen. However, it provides a pathway for producing hydrogen from carbon free renewable energy [5].

With the increasing scarcity of fossil fuels and increasing concerns over the environmental problems they cause, the use of renewable energy resources will likely increase and diversify. Geothermal energy appears to be a potential solution among other renewable energy sources [8]. Geothermal energy provides an affordable, clean method of generating electricity and providing thermal energy. In this regard, the use of geothermal energy for hydrogen production and liquefaction can prove to be effective option in the future hydrogen structure.

Jonsson et al. [10] investigated the feasibility of using geothermal energy for hydrogen production and estimated that using geothermal energy could avoid 16% of the work consumption for electrolysis and 2% for liquefaction. Sigurvinsson et al. [11] investigated the use of geothermal heat in high-temperature electrolysis (HTE) process. This HTE process includes heat exchangers and an electrolyses based on solid oxide fuel cell (SOFC) technology working in inverse, producing oxygen and hydrogen instead of consuming them. Mansilla et al. [12] studied a techno-economic optimization of the upper heat exchanger network in the high temperature electrolysis process for producing hydrogen. Heat obtained by coupling the process either to a high-temperature reactor or to a geothermal source. Ingason et al. [13] investigated the most economical ways of producing hydrogen solely via electrolysis from water, using electricity from hydro and geothermal power.

Valdimar et al. [14] presented a feasibility study exploring the use of geothermal energy for hydrogen production. They investigated a HOT ELLY high temperature steam electrolysis process operating between 800 and 1000°C. Using HOT ELLY process with geothermal steam at 200°C can reduce the hydrogen production cost by approximately 19%. Arnason et al. [15] described a path towards a future hydrogen energy economy in Iceland.

Kanoglu et al. [17] investigated the use of geothermal energy for hydrogen liquefaction. Three models were considered for the analysis including the use of geothermal power for liquefaction cycle, the use of absorption cooling system for precooling gas before liquefaction and a cogeneration option for which both geothermal electricity and geothermal heat for absorption system are used. Kanoglu et al. [18] investigated

energy, exergy, and exergoeconomic analysis of a geothermal assisted high temperature electrolysis process. Energy and exergy performance parameters such as heat transfer, power, exergy destruction, and exergy efficiencies were calculated. Yilmaz et al. [19] studied energy and exergy analysis of a PEM water electrolysis driven by geothermal power for hydrogen production. The first and second-law based performance parameters were identified for the considered system and the system performance was evaluated. Kanoglu et al. [20] developed four models for the use of geothermal energy for hydrogen production. These models were studied thermodynamically, and both reversible and actual (irreversible) operations of the models were considered. Yilmaz et al. [21] considered seven models for hydrogen production and liquefaction by geothermal energy, and their thermodynamic and economic analyses were performed. The amount of hydrogen production and liquefaction per unit mass of geothermal water and the cost of producing and liquefying a unit mass of hydrogen are calculated for each model. The effect of geothermal water temperature on the cost of hydrogen production and liquefaction were investigated.

In this paper, we consider the use of geothermal energy for hydrogen production, and present six models. These models are described and their basic thermodynamic evaluations are presented.

MODELS FOR GEOTHERMAL ENERGY USE IN HYDROGEN PRODUCTION

Fig. 1 shows six models for the use of geothermal energy for hydrogen production and liquefaction.

Model 1: Uses geothermal work output as the work input for an electrolysis process (Fig. 1a).

Model 2: Uses part of geothermal heat to produce work for electrolysis process and part of geothermal heat in an electrolysis process to preheat the water (Fig. 1b).

Model 3: Uses geothermal heat in an absorption refrigeration process to precool the gas before the gas is liquefied in a liquefaction cycle (Fig. 1c).

Model 4: Uses part of the geothermal water heat for absorption refrigeration to precool the hydrogen gas and part of the geothermal water heat to produce work with a binary geothermal cycle (for low temperature of geothermal water) and use it in a liquefaction cycle (Fig. 1d).

Model 5: Uses geothermal work output as the electricity input for a liquefaction cycle (Fig. 1e).

Model 6: Uses part of geothermal work for electrolysis and the remaining part for liquefaction (Fig. 1f).

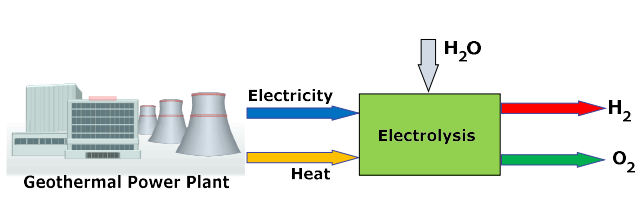

(Model 1)

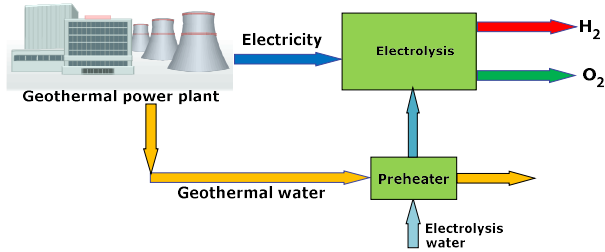

(Model 2)

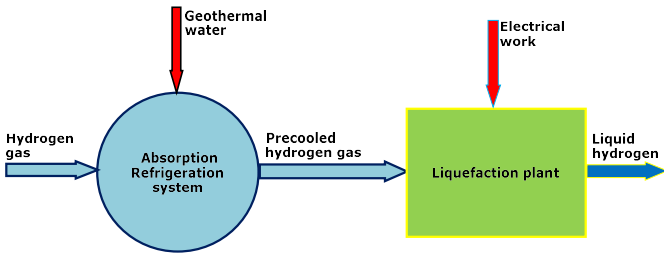

(Model 3)

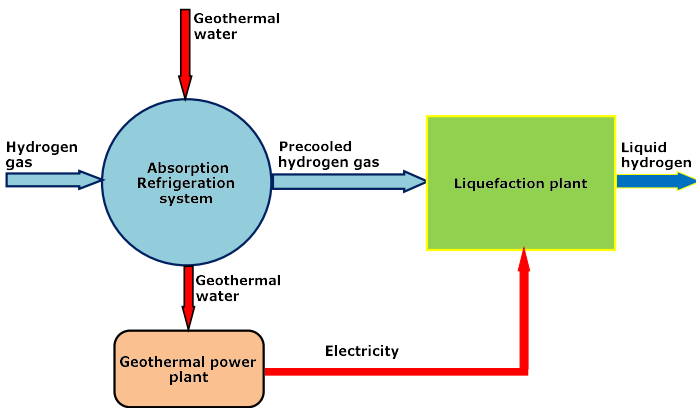

(Model 4)

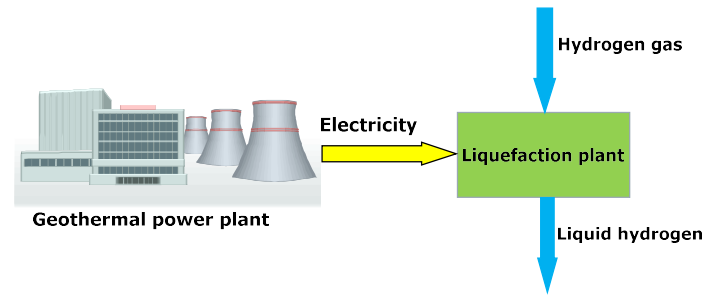

(Model 5)

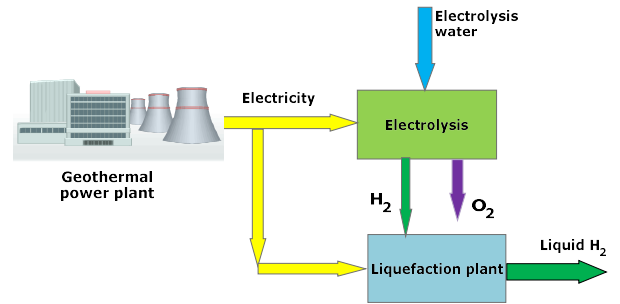

(Model 6)

Fig. 1. Thermodynamic models for the use of geothermal energy for hydrogen production and liquefaction.

THERMODYNAMIC ANALYSIS

Mass and energy balances for any control volume at steady state with negligible kinetic and potential energy changes can be expressed as:

$$\sum \dot{m}_i = \sum \dot{m}_e \quad (1)$$

$$\dot{Q} + \dot{W} = \sum \dot{m}_e h_e - \sum \dot{m}_i h_i \quad (2)$$

where \dot{Q} and \dot{W} are the net heat and work inputs, \dot{m} is the mass flow rate of the fluid stream, h is the enthalpy, and the subscripts i and e stand for inlet and exit.

The energy or thermal efficiency of a geothermal power plant can be expressed as

$$\eta = \frac{\dot{W}_{net,geo}}{\dot{m}_{geo}(h_{geo} - h_0)} \quad (3)$$

where $\dot{W}_{net,geo}$ is the net power output to the power plant, \dot{m}_{geo} is the mass flow rate of geothermal water. Here, geothermal energy input is expressed as the enthalpy of the geothermal

water with respect to environment state multiplied by the mass flow rate of geothermal water.

In the models, a simple alkaline water electrolysis unit is considered. Electrolysis process is a thermochemical process. A water electrolysis process can be expressed as

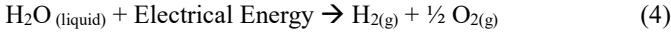

The electrode reactions are:

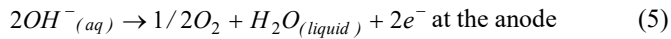

When the first law of thermodynamic is applied to the electrolysis process, the total energy demand for electrolysis is calculated as

$$\dot{W}_{\text{rev}} = \Delta G = \Delta H - T\Delta S \quad (6)$$

where ΔG is the electrical energy demand (change in Gibb's free energy) and $T\Delta S$ is the thermal energy demand (kJ/kmol H₂). The total energy demand ΔH is the theoretical energy required for water electrolysis without any losses. In real systems, losses are inevitable and the performance of the system concerned can be evaluated in terms of energy efficiency as

$$\eta = \frac{\dot{m}_{\text{H}_2} \text{LHV}}{\dot{W}_{\text{act,electrolysis}}} \quad (7)$$

where LHV is the lower heating value of hydrogen, \dot{m}_{H_2} is the flow rate of hydrogen, and $\dot{W}_{\text{act,electrolysis}}$ is the actual rate of power input for the electrolysis system.

For an ammonia-water absorption refrigeration cycle (ARC), the overall energy balance may be expressed as

$$\dot{W}_P + \dot{Q}_L + \dot{Q}_{\text{gen}} = \dot{Q}_A + \dot{Q}_H \quad (8)$$

where heat loss to the ambient is neglected. Here \dot{Q}_L is the rate of heat removed from the cooled hydrogen gas in the evaporator, \dot{Q}_{gen} is the rate of heat supplied by geothermal water in the generator, \dot{Q}_A is the absorber head load rate, and \dot{Q}_H is the rate of heat rejected to the warm environment in the condenser. The actual COP of the ARC is expressed as

$$\text{COP}_{\text{abs,act}} = \frac{\dot{Q}_{L,\text{ARC}}}{\dot{Q}_{\text{gen}} + \dot{W}_P} \cong \frac{\dot{m}_{\text{H}_2} \Delta h}{\dot{m}_{\text{geo}} (h_{\text{geo,in}} - h_{\text{geo,out}})} \quad (9)$$

where \dot{W}_P is the pumping power requirement, and it is neglected.

For the Claude liquefaction cycle, the total work input for the cycle per unit mass of liquefied hydrogen is

$$w_{\text{liq,act}} = \frac{w_{\text{comp}} + w_{\text{N}_2} - w_{\text{turb}}}{y_{\text{liq}}} \quad (10)$$

where y_{liq} is the fraction of hydrogen liquefied in the cycle. The total work consumption for liquefaction involves the work consumed by the hydrogen compressor as well as the work requirement for producing liquid nitrogen. The actual COP of Claude liquefaction cycle is given by

$$\text{COP}_{\text{liq,act}} = \frac{\dot{Q}_{L,\text{liq}}}{\dot{W}_{\text{liq}}} = \frac{\dot{m}_g h_g - \dot{m}_f h_f}{\dot{W}_{\text{comp}} + \dot{W}_{\text{N}_2} - \dot{W}_{\text{turb}}} \quad (11)$$

where $\dot{Q}_{L,\text{liq}}$ is the rate of heat rejection from the hydrogen gas during the liquefaction process and \dot{W}_{liq} is the power input for the liquefaction.

ANALYSIS AND RESULTS OF MODELS

For the analysis of hydrogen production models powered by geothermal energy, we assume an environment temperature of 25°C and an atmospheric pressure of 100 kPa. Thermophysical properties of the working fluids (geothermal water, ammonia-water, air, and hydrogen) are obtained from EES software with built-in thermodynamic property functions. We consider a liquid geothermal source at a temperature of 200°C with a mass flow rate of 100 kg/s.

Model 1

The details of this model is given in Fig. 2. In this model, a combined flash-binary geothermal power plant is considered. Geothermal liquid water coming out of the well is flashed to a lower pressure and resulting vapor is separated from the liquid. The vapor is expanded in a steam turbine, condensed, and reinjected. The liquid geothermal water from the separator is used as the heat source in the binary cycle. The working binary fluid is isobutane. The working fluid is completely vaporized by the heat of geothermal water in the heat exchanger. The vapor expands in the turbine, and then condensed in an air-cooled condenser before being pumped back to the heat exchanger to complete the cycle. The geothermal water leaving the heat exchanger is reinjected back to the ground. The power generated in the plant is used in a water electrolyzer to produce hydrogen gas.

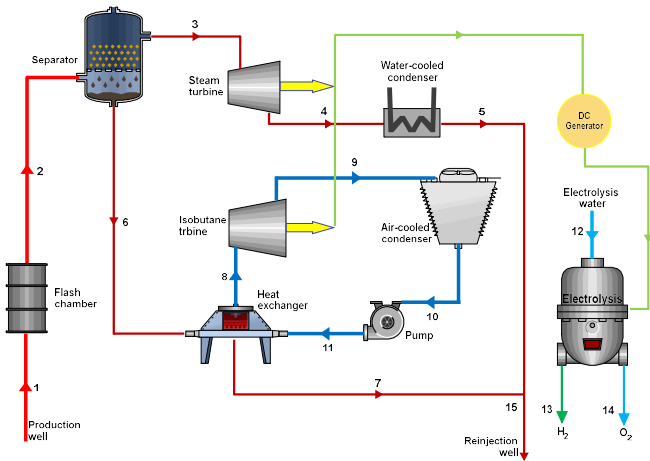

Fig.2. In Model 1, electricity is produced from a combined flash binary geothermal power plant and used in the electrolysis unit for hydrogen production.

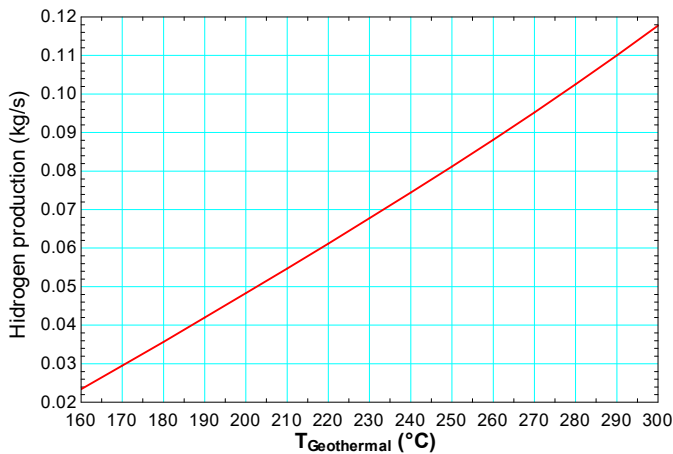

Fig. 3. Variation of hydrogen production rate in the electrolysis unit with respect to geothermal water temperature.

Under realistic operating conditions, 7572 kW power can be produced from the combined flash binary geothermal power plant. Taking the inlet state of the liquid to be 1 atm and saturated liquid, the actual electrolysis work input for the electrolysis of hydrogen is calculated as 156,865 kJ/kg. The power produced in the geothermal plant is used for the electrolysis process. In the electrolysis unit hydrogen can be produced at a rate of 0.04820 kg/s. The energy efficiencies of the geothermal power plant, the electrolysis system, and the overall system are determined to be 11.4%, 76.6%, 7.76%, respectively.

Fig. 3 shows variation of hydrogen production rate in the electrolysis unit with respect to geothermal water temperature. Fig. 4 shows variation of energy efficiency of the overall system as a function of geothermal water temperature. As the geothermal temperature increases the rate of hydrogen production and energy efficiency increase.

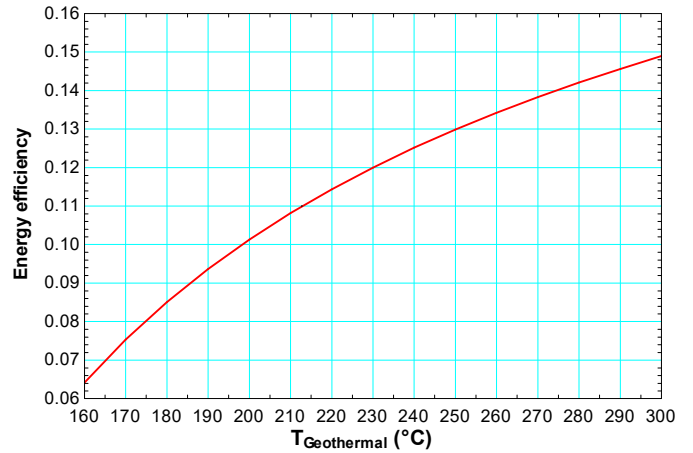

Fig. 4. Energy efficiency of the overall system with respect to geothermal water temperature.

Model 2

The details of Model 2 is given in Fig. 5. The system is similar to Model 1 except that the electrolysis water is heated by geothermal water before the electrolyses process. A higher water temperature for the electrolysis process results in a reduction in electricity consumption.

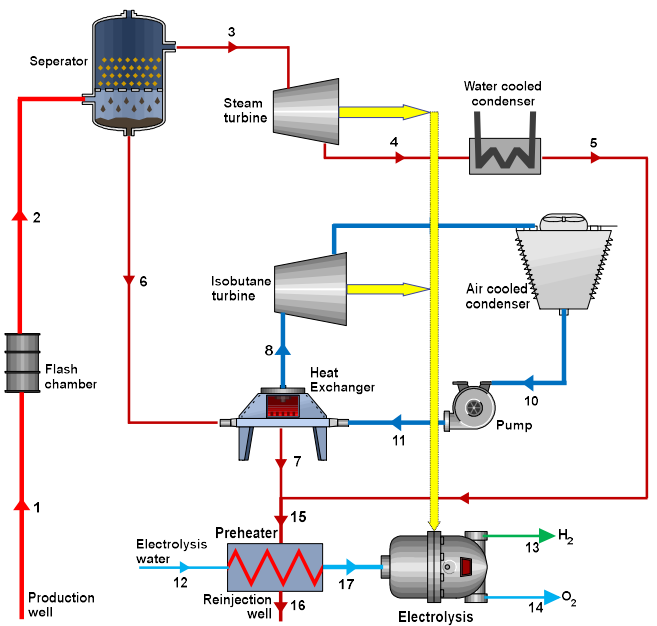

Fig. 5. In Model 2, electricity is produced in a combined flash binary geothermal power plant and water is heated by the used geothermal water before the electrolysis unit.

In this model, 7572 kW power can be produced in the geothermal power plant. The electrolysis water can be preheated to 70 °C by the geothermal water leaving the power

plant and hydrogen can be produced at a rate of 0.04982 kg/s. Taking the inlet state of the liquid to be 1 atm and a saturated liquid, the actual electrolysis work input for the electrolysis of hydrogen can be calculated to be 151,979 kJ/kg. The energy efficiencies of the binary geothermal power plant, the electrolysis unit, and the overall system are 11.4%, 79.1%, and 8.01%, respectively.

Fig. 6 shows variations of hydrogen production rate and electrolysis water temperature as a function of geothermal water temperature. Both hydrogen production and electrolysis temperature increase with geothermal water temperature. Fig. 7 shows that energy efficiency of the overall system also increases with geothermal water temperature.

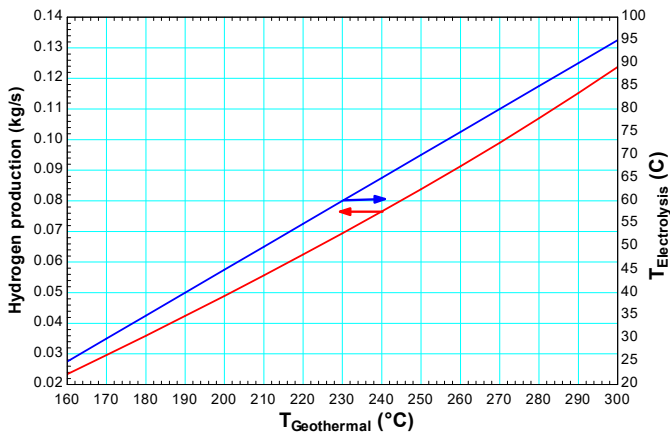

Fig. 6. Variation of hydrogen production rate and electrolysis water temperature with geothermal water temperature.

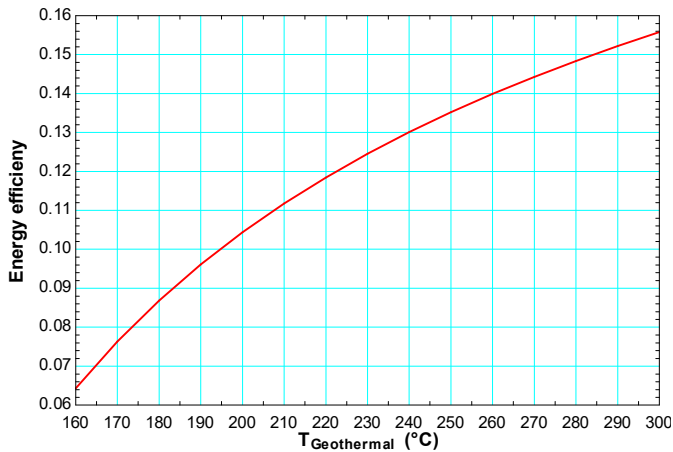

Fig. 7. Energy efficiency of the overall system with respect to geothermal water temperature.

Model 3

The detailed schematic of Model 3 is given in Fig. 8. Geothermal hot water provides the thermal energy requirement

for the absorption refrigeration system. In order to reduce work input in the hydrogen liquefaction process, hydrogen gas is cooled in an ammonia-water absorption system before being liquefied in the Claude cycle. Pure ammonia vapor leaving the evaporator is absorbed by water in the absorber. The solution in the absorber should be continuously cooled by a water stream to facilitate the absorption of ammonia. The ammonia-rich liquid solution is first heated in the regenerator by the returning stream with low ammonia fraction, then pumped to the generator. In the generator, ammonia evaporates as a result of heat transfer from the hot geothermal water. Any remaining liquid in the ammonia is returned to the rectifier. The water-ammonia solution that is poor in ammonia is returned to the absorber by passing through the regenerator and expansion valve. Pure ammonia flows through the condenser where heat is removed from the cycle. The pressure of liquid ammonia is reduced to match the evaporator pressure in the expansion valve. As the liquid-vapor mixture of ammonia flows in the evaporator, it absorbs heat from cold hydrogen gas, and it leaves the evaporator as a vapor. The cooled hydrogen gas leaves the evaporator and enters the compressor of the Claude cycle.

The Claude hydrogen liquefaction cycle is shown on the right side of Fig. 8. The Claude cycle is an efficient process for hydrogen liquefaction as it uses a turbine for producing work, thereby reducing work input in the cycle. The expansion through an expansion valve is a highly irreversible process. In the Claude cycle, energy is removed from the gas stream by allowing it to do some work in a turbine. Compared to an isenthalpic expansion process in a throttling valve, a lower temperature is attained in a turbine exit [26].

In the Claude liquefaction cycle, the hydrogen gas is first compressed to a high pressure at state 13, and then passed through the first heat exchanger. It is further cooled by liquid nitrogen. Some of the gas is then diverted to a turbine; it is expanded in the turbine; and reunited with the return stream at state 18. The stream to be liquefied continues the second and third heat exchangers, and is finally expanded through an expansion valve to the liquid receiver. The liquid hydrogen is collected as the product of the cycle. Cold hydrogen gas flows through the third heat exchanger to cool the high pressure gas. It then passes through the second and first heat exchangers. Finally, it mixes with precooled hydrogen gas from the absorption cycle and enters the compressor.

Model 3 is analyzed thermodynamically using appropriate performance parameters. Under realistic operating conditions 39,080 kW heat can be supplied by geothermal water in the absorption refrigeration system. Hydrogen gas can be cooled to -26.9°C at a rate of 29.53 kg/s in the absorption unit. The coefficient of performance (COP) of the ammonia-water refrigeration system is determined to be 0.556. The COP of the Claude liquefaction system is 0.0120. For the overall system, the COP is 0.0159. Also, precooling hydrogen gas in an

absorption refrigeration cycle powered by geothermal heat decreases the work consumption in the liquefaction process by 25.4%.

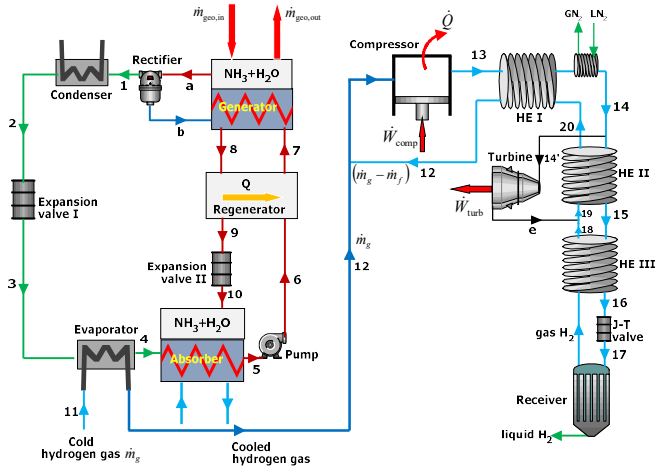

Fig. 8. In Model 3, geothermal heat is used in an absorption refrigeration process to precool hydrogen gas before the gas is liquefied in a liquefaction cycle (Claude cycle).

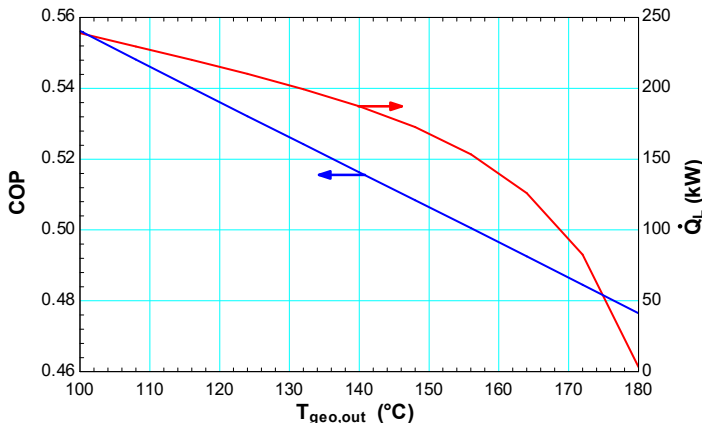

Fig. 9. Variation of the COP and cooling load as a function of geothermal water temperature at the generator outlet.

Fig. 9 shows variation of the COP and cooling load as a function of geothermal water temperature at the generator outlet. As the geothermal temperature increases both the COP and the cooling load decreases since this corresponds to a lower use of geothermal heat in the generator. Fig. 10 shows variation of liquefaction work as a function of compression pressure in the Claude liquefaction cycle. This parametric study results in an optimum compression pressure that minimizes liquefaction work. Fig. 11 shows variation of liquefaction work as a function of hydrogen gas temperature at the exit of the absorption cycle. As the cooled gas temperature decreases the liquefaction work decreases. Therefore, hydrogen temperature should be as low as possible before the liquefaction process.

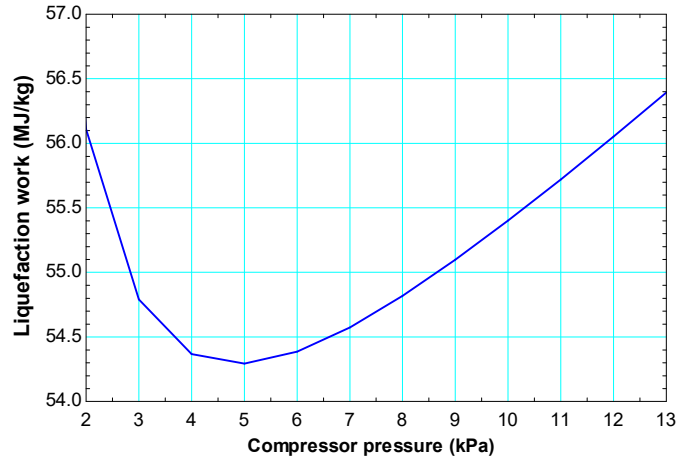

Fig. 10. Liquefaction work as a function of compression pressure in the Claude liquefaction cycle.

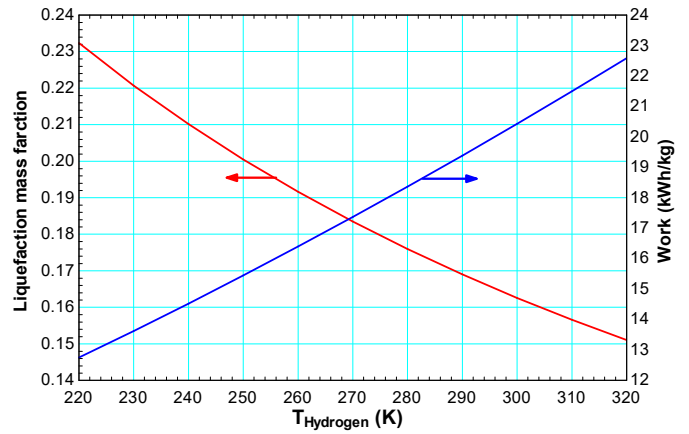

Fig. 11. Liquefaction work as a function of the cooled hydrogen gas temperature.

Model 4

The schematic of Model 4 is given in Fig. 12. This model is similar to Model 3 except that geothermal water leaving the absorption system is used to produce power in a binary geothermal power plant. The power output of the plant is used to provide compression work in the Claude cycle.

By using a geothermal water source at 200°C at a rate of 100 kg/s, hydrogen gas can be cooled to -26.9°C at a rate of 29.53 kg/s in the absorption system. The COPs of the absorption refrigeration cycle and the Claude cycle are determined to be 0.556 and 0.0120, respectively. For the overall system, the COP is 0.0159.

The minimum work requirement in the Claude liquefaction cycle is calculated to be 9272 kJ/kg H₂ (or 2.57 kWh/kg H₂) for an inlet temperature of -26.9°C and a pressure of 100 kPa. The power of liquefaction for a hydrogen mass flow rate of 1 kg/s is determined to be 54,301 kW. For the operation of the cycle, out of 1 kg/s hydrogen entering the system, only 0.0205

kg/s can be liquefied. The work consumption in the liquefaction cycle is calculated as 54,301 kJ/kg H₂ (or 15.08 kWh/kg H₂) for a gas inlet temperature of -26.9°C. If we use an inlet gas temperature of 25°C, the work consumption becomes 72,785 kJ/kg H₂ (or 20.22 kWh/kg H₂). Fig. 13 shows that geothermal power output and liquefied hydrogen rate increase as the geothermal water temperature increases.

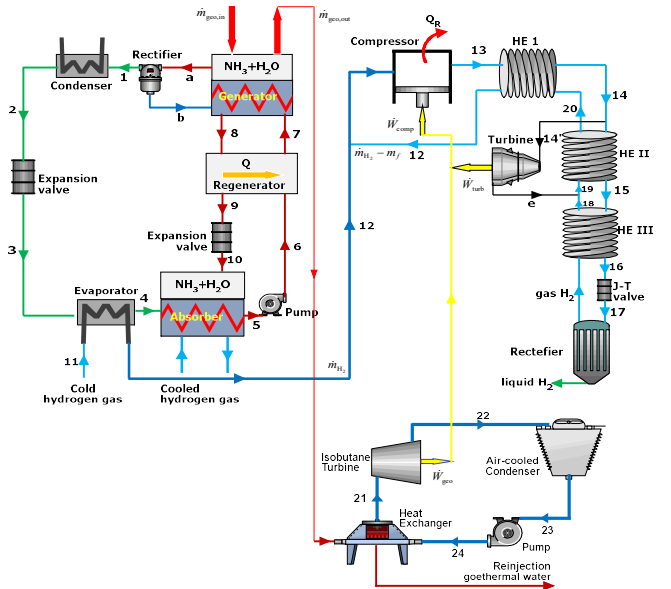

Fig. 12. In Model 4, hydrogen is cooled in an absorption cycle, power is produced in a binary geothermal power plant, and hydrogen is liquefied in the Claude cycle.

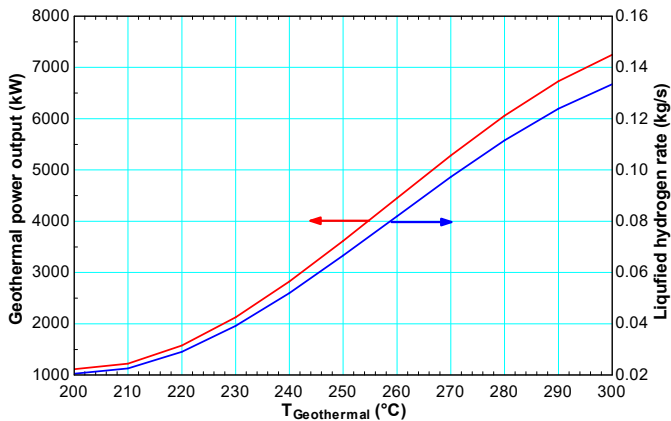

Fig. 13. Variation of geothermal power output and liquefied hydrogen rate with respect to geothermal water temperature.

Model 5

The schematic of Model 5 is given in Fig. 14. A flash binary geothermal power plant is used to produce power and this power is used for hydrogen liquefaction in the Claude cycle.

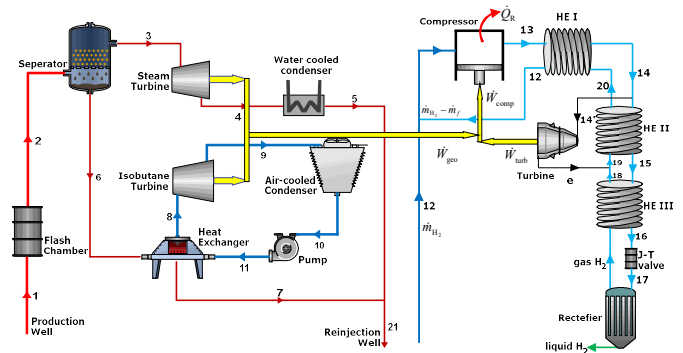

Fig. 14. In model 5, electricity is produced in a geothermal power plant and used in the Claude cycle.

Under realistic operating conditions, 7572 kW power can be produced in a combined flash binary geothermal power plant. The minimum work requirement in the Claude liquefaction cycle is calculated to be 11,996 kJ/kg H₂ (or 3.242 kWh/kg H₂) for an inlet temperature of 25°C and a pressure of 100 kPa. The actual power of liquefaction for a hydrogen mass flow rate of 1 kg/s is determined to be 72,522 kW (or 20.14 kWh/kg H₂). For the actual operation of the cycle, out of 1 kg/s hydrogen entering the system, only 0.1044 kg/s can be liquefied. The energy efficiencies of the geothermal power plant and the overall system are 10.4% and 5.25%, respectively. Fig. 15 shows that geothermal power output and liquefied hydrogen rate of the system increase with increasing geothermal water temperatures.

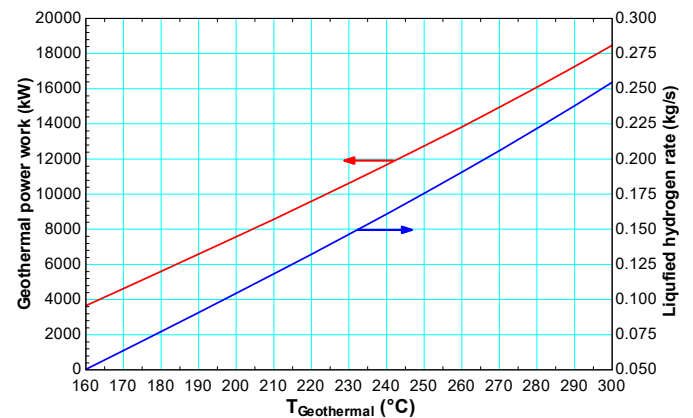

Fig. 15. Variation of geothermal power output and liquefied hydrogen rate with respect to geothermal water temperature.

Model 6

The operation of Model 6 is depicted in Fig. 16. In this model, hydrogen production and liquefaction by a geothermal source is accomplished. The electrical power of electrolysis and liquefaction processes is supplied from the geothermal power plant. The geothermal work is used for electrolysis to produce

hydrogen gas and the remaining power is used for the liquefaction of hydrogen gas.

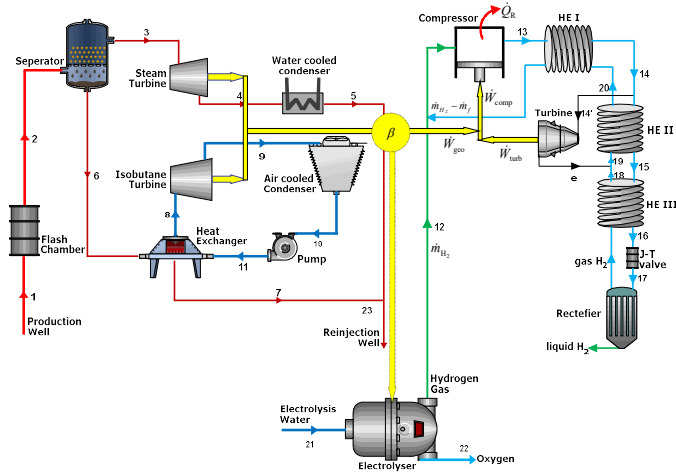

Fig. 16. In Model 6, part of geothermal power is used for the electrolysis process and the remaining part for liquefaction.

In Model 1, the work for electrolysis is determined to be 156,860 kJ/kg H₂ and the work required to liquefy one kg of hydrogen is determined to be 72,522 kJ/kg H₂. The geothermal power output is 7572 kW. Out of this produced power, 4072 kW is used for electrolysis and the remaining 3500 kW for liquefaction process. The energy efficiency is calculated to be 5.6%. Fig. 17 shows that the rates of hydrogen production and liquefaction increase with increasing geothermal water temperature.

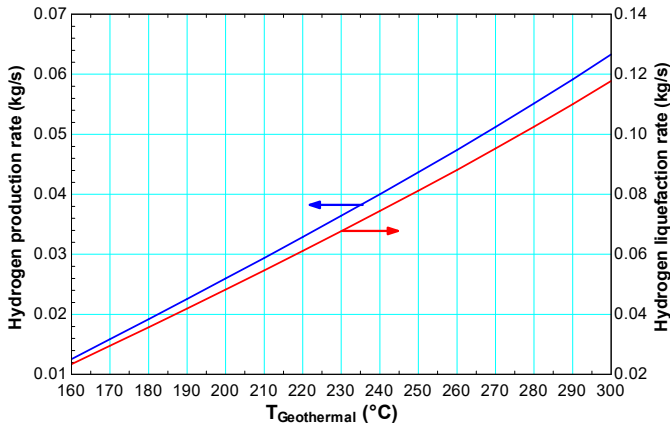

Fig. 17. Variation of hydrogen production and liquefaction rates with respect to geothermal water temperature.

CONCLUSIONS

Certain thermodynamic models that can be used in hydrogen production and liquefaction by geothermal energy are introduced and basic thermodynamic analysis of these models is presented. In these models, the alternatives such as the direct

use of geothermal heat and/or power are considered. The use of geothermal electricity for supplying compressor power in liquefaction plant and precooling hydrogen gas in an absorption refrigeration system before liquefaction are examined. For hydrogen production the conventional electrolysis methods are considered. In some models, preheating water before electrolysis is considered. Basic thermodynamic performance of the models are studied and the effect of geothermal water temperature on the amount of hydrogen production and liquefaction as well as energy efficiency are investigated. It is observed that as the temperature of geothermal water increases the amount of hydrogen production and liquefaction as well as energy efficiency increase.

ACKNOWLEDGMENTS

This study is sponsored by The Scientific and Technological Research Council of Turkey (TÜBİTAK) under the project 113M207. This support is greatly appreciated.

NOMENCLATURE

COP	coefficient of performance
G	Gibbs function, kJ/kmol
h	specific enthalpy, kJ/kg
H	enthalpy, kJ/kmol
LHV	lower heating value, kJ/kg
\dot{m}	mass flow rate, kg/s
\dot{Q}	heat, kW
s	specific entropy, kJ/kg K
S	entropy, kJ/kmol K
T	temperature, °C or K
T_0	ambient temperature, °C or K
T_s	source temperature, °C or K
T_L	refrigeration temperature, °C or K
w	work per unit mass, kJ/kg
\dot{W}	work, kW
y	fraction of gas liquefaction

Greek Letters

β	the ratio of electrolysis work to the liquefaction work
Δ	finite change in quantity
η	energy efficiency

Subscripts

act	actual
ARC	absorption refrigeration cycle
e	exit conditions
elect	electrolysis
i	inlet conditions
gen	generation

geo	geothermal
H ₂	hydrogen
H ₂ O	water
liq	liquefaction
rev	reversible
1,2,3...	state numbers
0	reference state

REFERENCES

- [1] Hotza, D. ve Diniz da Costa, J.C., Fuel cells development and hydrogen production from renewable resources in Brazil, *International Journal of Hydrogen Energy* 33, 4915-4935, 2008.
- [2] Scott DS. Smelling land: the hydrogen defense against climate catastrophe. Canadian Hydrogen Association, <www.h2.ca>; 2012.
- [3] Hand TW. Hydrogen production using geothermal energy, theses and dissertations: Utah State University; 2008.
- [4] Konieczny A, Mondal K, Wiltowski T, Dydo P. Catalyst development for thermocatalytic decomposition of methane to hydrogen. *International Journal of Hydrogen Energy* 2008; 33(1):264e72.
- [5] Simpsona AP, Lutz AE. Exergy analysis of hydrogen production via steam methane reforming. *International Journal of Hydrogen Energy* 2007;32(18):4811e20.
- [6] Simpsona AP, Lutz AE. Exergy analysis of hydrogen production via steam methane reforming. *International Journal of Hydrogen Energy* 2007;32(18):4811-20.
- [7] Konieczny A, Mondal K, T. Wiltowski T, Dydo P. Catalyst development for thermocatalytic decomposition of methane to hydrogen. *International Journal of Hydrogen Energy* 2008; 33(1): 264-72
- [8] Mohan SV, Mohanakrishna G, Ramanaiah SV, Sarma PN. Simultaneous biohydrogen production and wastewater treatment in biofilm configured anaerobic periodic discontinuous batch reactor using distillery wastewater. *International Journal of Hydrogen Energy* 2008; 33(2): 550-8.
- [9] Barbier E. Nature and technology of geothermal energy: a review. *Renewable and Sustainable Energy Reviews-An International Journal* 1997;1(2):1-69.
- [10] Jonsson VK, Gunnarsson RL, Arnason B, Sigfusson TI. The feasibility of using geothermal energy in hydrogen production. *Geothermics* 1992;21:673-81.
- [11] Sigurvinsson J, Mansilla C, Lovera P, Werkoff F. Can high temperature steam electrolysis function with geothermal heat? *International Journal of Hydrogen Energy* 2007;32(9):1174-82.
- [12] Mansilla C, Sigurvinsson J, Bontemps A, Maréchal A, Werkoff F. Heat management for hydrogen production by high temperature steam electrolysis. *Energy* 2007;32(4):423-30.
- [13] Ingason HT, Ingolfsson HP, Jensson P. Optimizing site selection for hydrogen production in Iceland. *International Journal of Hydrogen Energy* 2008;33(14):3632-43.
- [14] Valdimir K., Jonsson B., Ragnar R., Arnason B. (1992). The Feasibility of Using Geothermal Energy in Hydrogen Production. *Geothermics*, 21, (5/6), 673-681.
- [15] Arnason, B., Sigfusson, T.I. ve Jonsson, V.K., New concepts in hydrogen production in Iceland, *International Journal of Hydrogen Energy* 18(11), 915-919, 1993.
- [16] Sigurvinsson, J., Mansilla, C., Lovera, P. ve Werkoff, F., Can high temperature steam electrolysis function with geothermal heat?, *International Journal of Hydrogen Energy* 32 (9), 1174-1182, 2007.
- [17] Kanoglu M., Dincer I., Rosen M.A. Geothermal energy use in hydrogen liquefaction. *International Journal of Hydrogen Energy* 32.17 (2007): 4250-4257.
- [18] Kanoglu M., Ayanoglu A., Abusoglu A. Exergoeconomic assessment of a geothermal assisted high temperature steam electrolysis system. *Energy*. 2011; 36(7):4422-4433.
- [19] Yilmaz C., Kanoglu M. Thermodynamic evaluation of geothermal 376 energy powered hydrogen production by PEM water electrolysis. *Energy* 2014 (69); 592-602.
- [20] Kanoglu M., Bolatturk A., Yilmaz C. Thermodynamic analysis of models used in hydrogen production by geothermal energy. *International Journal of Hydrogen Energy* 35.16 (2010): 8783-8791.
- [21] Yilmaz C., Kanoglu M., Boltturk A., Gadalla M. Economics of hydrogen production and liquefaction by geothermal energy. *International journal of hydrogen energy* 37.2 (2012): 2058-2069.