

This paper was recommended for publication in revised form by Regional Editor Derya Burcu Özkan

ENERGY AND EXERGY ANALYSIS OF COGENERATION SYSTEM WITH BIOGAS ENGINES

***Nadezhda Doseva**
Technical University of Varna
Varna, Bulgaria

Daniela Chakyrova
Technical University of Varna
Varna, Bulgaria

Keywords: Biogas internal combustion engines, Cogeneration system, Energy, Exergy, Thermodynamic performance assessment parameters

** Corresponding author: N. Doseva, Phone: +359 899 247 045
E-mail address: nadezhda.doseva@tu-varna.bg*

ABSTRACT

In this paper, an existing cogeneration system driven by biogas internal combustion engines (ICE) is a subject of an investigation by energy and exergy analyses. The system is installed in the Varna Wastewater Treatment Plant (Varna WWTP), Bulgaria and its purpose is to utilize the methane produced as a byproduct of the solids stabilization process at Varna WWTP. Otherwise, the produced methane would pollute the environment. The presented paper has been organised in the following way: first, in order to define the basic thermodynamic parameters on the stations of the cogeneration system streams, the energy balance equations for each component of the system are formulated. Then, the rate of exergy destruction within the the k th system component is calculated using the exergy balance equations. Moreover, according to the methodology introduced in (The European Education Tool on Cogeneration System (EDUCOGEN), 2001), energy efficiency, power to heat ratio, energy saving ratio, energy efficiency used under the Public Utilities Regulatory Policy Act (PURPA efficiency) are defined for the cogeneration system. The same thermodynamic performance assessment parameters (without PURPA efficiency) are determined on exergy base. In addition to the thermodynamic performance assessment parameters of the cogeneration system, a detailed exergy analysis on the component level is performed. To our knowledge, there has been little discussion about exergy efficiency of ICE based cogeneration systems for use with biogas from wastewater treatment plants. To address this niche in the global research work, in this investigation is suggested detailed exergy analysis

permitting us to assess thermodynamic performance of similar class energy conversion systems.

INTRODUCTION

In recent years in Bulgaria, there has been an increasing interest in applications of cogeneration technologies using biogas fuel. Similar systems has built and put into operation in Wastewater Treatment Plant Kubratovo, Stara Zagora, Varna, “Svilozha” JSC (Svishtov), Biogas Plant Momchil and elsewhere. These facts create prerequisites for in-depth analyses of the benefits and performance assessment parameters of the combined heat and power (CHP) technologies using biofuels in order to achieve national sustainable energy development.

In relation to the Bulgarian energy policy, there is a legal framework with regard to the energy efficiency of industrial energy systems. It requires determining the current energy consumption of the analyzed system and prescribing appropriate energy saving measures. When applying these measures, however, a significant decreasing of the energy consumption and increasing of the systems energy performance assessment parameters is required. The exergy analysis is a possible approach for carrying out these tasks. Furthermore, a renewed Regulation regarding electricity produced in cogeneration installations has been valid since July 1, 2013. The amendment to this regulation consists in an increasing of reference energy efficiency of CHP plant.

The China’s provisions on the development of cogeneration (2000) also prescribe reference values of energy performance assessment parameters. For example, it specifies the minimum

thermal efficiency and the minimum power to heat ratio of cogeneration plants. (China Energy Conservation Investment Corporation, 2001).

The National Energy Act of USA specifies a very interesting minimum efficiency standard for cogeneration units – the PURPA efficiency. In order to calculate its numerical value, we must be taken an account only half of the heat energy of the product. If the CHP plant has PURPA efficiency greater than 42.5%, it can be defined as high efficiency system (U.S. EPA OAR, 2005).

The energy analysis and the determined values of the performance assessment parameters, however, assessed only quantitatively the process of energy transformation, without taking into account the quality of different types of energy. This can be achieved by applying of the exergy analysis and thus to comply with the second law of thermodynamics.

There are a range of technologies that can be applied to the cogeneration system and many researchers draw attention to design and thermodynamic performance evaluation of widely use configuration of CHP system. For example, Abusoglu et al. (2009b) and Yildirim et al. (2012) investigated from exergetic point of view a cogeneration system based on compression ignition (CI) internal combustion engine (ICE). Balli et al. (2010b) calculated the exergy costs of each product generated by a trigeneration system, i.e. it conducted thermoeconomic (or exergoeconomic) analysis of the system. The subject of an investigation in one study by Bonnet and co-workers (2005) is a micro-cogeneration system based on an Ericsson engine. In another paper, Ozkan et al. (2012) analyzed gas turbine based cogeneration system and in a study conducted by More et al. (2014) a steam turbine is the prime mover. Badami and Mura (2010) carried out an exergy analysis of the combined cycle composed of a reciprocating ICE, which is used as the topping cycle, and water Rankine cycle (RC), which operates on the exhaust gases from the ICE, as the bottoming cycle.

So far, however, there has been little discussion about second law efficiency of biomass cogeneration systems (Fagbenle, R., Oguaka, A. et al., 2007). At the same time a large and growing body of literature has investigated their prime movers – internal combustions engines fuelled biofuels: Caliskan, Tat et al. (2009) investigated the effect of varying dead state temperature on the exergy efficiency of high-oleic methyl ester (HOME) fuelled in compression ignition (CI) engine; the variations in second law efficiency of air standard Otto cycle with the change in compression ratio are demonstrated by Kamboj and Karimi (2013); the effect of different fuel types on exergy efficiency is investigated by Sekmen et al. (2011), Rakopoulos and Kyritsis (2001a, 2001b).

This paper provides the methodology for detailed analysis for the exergetic evaluation of an ICE based cogeneration systems for use with biogas from wastewater treatment plant. The methodology is applied to the analyzed system in the following order: at the beginning, in order to define the basic

thermodynamic parameters on the stations of the cogeneration system streams, the energy balance equations for each component of the system are formulated. Next, the rate of exergy destruction within the the k th system component is calculated using the exergy balance equations. Finally, according to the methodology introduced in (The European Education Tool on Cogeneration System (EDUCOGEN), 2001) and (United States Environmental Protection Agency Office of Air and Radiation (US EPA OAR, 2005), energy efficiency, power to heat ratio (PHR), fuel energy saving ratio (FESR), energy efficiency used under the Public Utilities Regulatory Policy Act (PURPA efficiency) are defined for the cogeneration system. Furthermore, these parameters (without PURPA efficiency) are expressed on exergy base. In addition, a detailed assessment on component level is conducted: it is calculated parameters, such as relative exergy consumption ratio, productivity lack ratio and exergetic improvement potential.

Performing the methodology described above, the main goal of this paper is achieved, namely: comparison of the results obtained from calculations of energy and exergy performance assessment parameters and formulating of conclusions about ability of the suggested methodology for in-depth evaluation of ICE based cogeneration systems for use with biogas from wastewater treatment plants.

SYSTEM DESCRIPTION

System description

This study is made for a cogeneration plant driven by biogas ICE and its purpose is to utilize the methane produced as a by-product of the solids stabilization process at Varna WWTP. The plant consists of two CHP modules, each of which is driven by internal combustion engines burned biogas - model Cento T300 SP BIO+ZP (Tedom). The plant produced electrical energy and hot water. The electricity is generated by two, biogas engine actuated generator set. Each of the biogas engines – generators sets produce 320kW electricity at 100% of output. In the heat exchanger of the plant (HEX), high temperature exhaust gas energy is used to heat water. Thus, the produced hot water has mass flow rate 7.6 kg/s and maximal heat rate is 2 x 322 kW. The flow diagram of the cogeneration plant is illustrated in Figure 1.

Operating conditions

The current thermodynamic model of the cogeneration plant was made for typical operation conditions of the system, namely 75% of total electrical output. For these conditions the system produces 240kW electricity. The heat energy consumption depends on thermal needs of mesophilic fermentation process, occurring within the digesters. In the produced heat rate is 279.976 kW, considered ISO day and system operating condition,

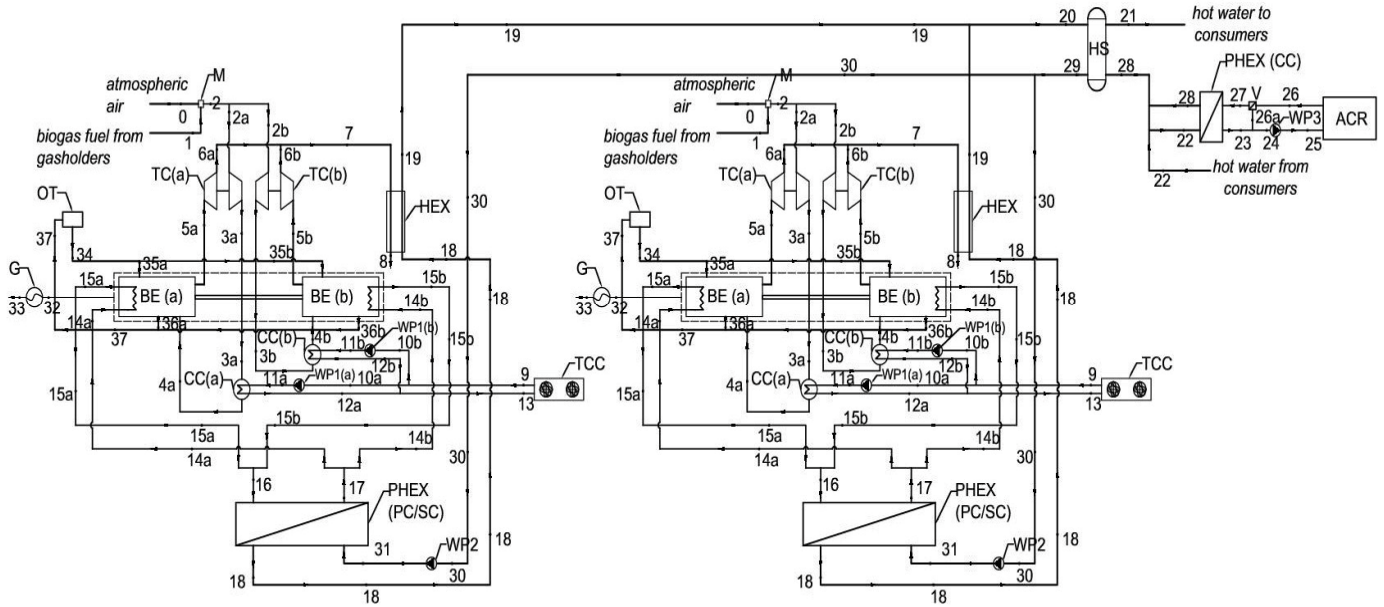

Figure 1. A schematic representation of the analyzed cogeneration system

M – mixer; TC(a), TC(b) – turbochargers; BE(a), BE(b) – internal combustion engines; CC(a), CC(b) – charge coolers; WP1(a), WP1(b) – technological circuit water pumps; TCC – technological circuit cooler; PHEX (PC/SC) – plate heat exchanger from secondary circuit; WP2 – secondary circuit water pump; HEX - heat exchanger; G – generator, OT – oil tank; HS – hydraulic separator; PHEX (CC) – plate heat exchanger from cooling circuit; V – 3 –way valve; WP3 – cooling circuit water pump; ACR – air – cooled radiator.

Assumptions made

In this study, the assumptions made include:

- (i) The cogeneration system operates in a steady-state;
- (ii) The ideal gas model is applied to the air, biogas, air-fuel mixture and combustion gases. Antifreeze, lube oil and water are considered as incompressible fluids;
- (iii) The kinetic and potential changes of energy and exergy are negligible;
- (iv) The mixer, compressor, turbine, water pumps and hydraulic separator are considered as adiabatic systems;
- (v) Heat loss rate and pressure drop for the pipelines connecting the various units of the cogeneration system is negligible;
- (vi) Pressure drop for the hydraulic separator (HS) and oil circuit is negligible;
- (vii) The reference temperature, pressure and relative humidity of air are taken at ISO day: 288.15K, 1.013bar and 60%;
- (viii) Air composition at ISO day is: 77.48 % N₂, 20.59% O₂, 0.03% CO₂, 1.18% H₂O(g) (Bejan et al., 1996);
- (ix) The energetic and exergetic analyses are made on the lower heating value (LHV) basis of biogas. The composition and LHV of obtained in Varna Wastewater Treatment Plant biofuel are given in Table 1.
- (x) The two parts of the cogeneration system (specified in Fig.1 by the symbol “a” and “b”) and the two CHP modules are operated in a similar manner.

Table 1. Biogas composition and LHV

Component	Volume (%)	Mass (%)	LHV (kJ/kg)
CH ₄	65	40.4	50050
CO ₂	35	59.6	-
Total	100	100	20204.8

The assumptions made idealize the model and thus the results differ from actual thermodynamic parameters on the stations of the cogeneration system streams. In a consequence of the assumptions made, the obtained results are closer to the ideal thermodynamic model of the system than to the actual one and the values of the thermodynamic performance assessment parameters are lower than actual, due to these assumptions. Nevertheless, such assumptions are useful, because simplifying significantly the problem.

Thermodynamic model of the cogeneration system with a biogas engine

The thermodynamic parameters, specific enthalpy, entropy and exergy data for the cogeneration system streams are listed in Table 2, according to their state numbers as defined in Figure 1. The cogeneration system is divided into subsystems (control volumes) as shown schematically in Table 3. The energetic and exergetic relations of these control volumes are also presented in this table. These balance equations are formulated on the basis of the energy and exergy rate balances for control volume at steady state (Moran and Shapiro, 2006):

$$\dot{Q}_{in} + \dot{W}_{in} + \sum_{in} \dot{m}_{in} e_{in} = \dot{Q}_{out} + \dot{W}_{out} + \sum_{out} \dot{m}_{out} e_{out} \quad (1)$$

$$\sum_k \left(1 - \frac{T_0}{T_k} \right) \cdot \dot{Q}_k - \dot{W}_k + \sum_{in} \dot{m}_{in} \varepsilon_{in} - \sum_{out} \dot{m}_{out} \varepsilon_{out} - \dot{E}x_D = 0 \quad (2)$$

Table 2. Thermodynamic properties on the characteristic stations of the cogeneration system

Station№	Fluid	\dot{m} , kg / s	T , K	p , bar	h , kJ / kg	s , kJ / (kgK)	ε , kJ / kg
0	Air	0.412	288.15	1.013	293.168	6.88957	2.095
1	Biogas	0.035	293.15	8.0	410.405	7.097	21460.16
2	Air-fuel mixture	0.447	288.67	1.05611	302.3846	7.03161	1657.969
2a, 2b	Air-fuel mixture	0.2235	288.67	1.05611	302.3846	7.03161	1657.969
3a, 3b	Air-fuel mixture	0.2235	380.551	2.0	405.57	7.13732	1729.637
4a, 4b	Air-fuel mixture	0.2235	338.15	1.98	354.532	6.968	1729.082
5a, 5b	Combustion gases	0.2235	835.15	2.9	969.6741	7.924	681.5913
6a, 6b	Combustion gases	0.2235	750.872	1.758	858.721	7.94148	565.4266
7	Combustion gases	0.447	750.872	1.758	858.721	7.94148	565.4266
8	Combustion gases	0.447	473.15	1.562	530.494	7.448	384.3306
9	Antifreeze	3.8	313.15	1.27	412.981	3.33788	15159.09
10a, 10b	Antifreeze	1.9	313.15	1.27	412.981	3.33788	15159.09
11a, 11b	Antifreeze	0.7942	313.213	2.915	413.162	3.33845	15159.11
12a, 12b	Antifreeze	0.7942	318.15	1.9	427.338	3.38365	15159.804
13	Antifreeze	3.8	318.15	1.9	427.338	3.38365	15159.804
14a, 14b	Antifreeze	1.0	357.341	0.87	353.4072	5.10406	5524.66
15a, 15b	Antifreeze	1.0	363.15	0.77	375.33	5.16543	5528.29
16	Antifreeze	2.0	363.15	0.77	375.33	5.16543	5528.29
17	Antifreeze	2.0	357.341	0.87	353.4072	5.10406	5524.66
18	Water	3.8	340.905	3.405	178.815	4.44303	184.973
19	Water	3.8	353.15	3.205	230.165	4.58974	192.582
20	Water	7.6	353.15	3.205	230.165	4.58974	192.582
21	Water	7.053	353.15	3.205	230.165	4.58974	192.582
22	Water	7.053	343.68	2.415	190.454	4.476	186.782
23	Antifreeze	4.626	319.95	0.4779	432.362	3.39967	15158.637
24	Antifreeze	9.785	309.879	0.43	403.592	3.30792	15158.637
25	Antifreeze	9.785	309.9	1.078	403.592	3.30792	15158.641
26	Antifreeze	9.785	304.9	0.7229	389.495	3.26171	15158.318
26a	Antifreeze	5.159	304.9	0.7229	389.495	3.26171	15158.318
27	Antifreeze	4.626	304.95	0.5779	389.4955	3.2618	15158.177
28	Water	7.053	336.96	2.37	162.306	4.394	183.08252
29	Water	7.6	338.128	2.37	167.1865	4.40845	183.655
30	Water	3.8	338.128	2.37	167.1865	4.40845	183.655
31	Water	3.8	338.15	3.508	167.303	4.40873	183.68777
34	Lube oil	0.71	326.973	0.55	73.876	0.237	3.356
35a, 35b	Lube oil	0.355	326.973	0.55	73.876	0.237	3.356
36a, 36b	Lube oil	0.355	341.973	0.55	120.035	0.376	8.042
37	Lube oil	0.71	341.973	0.55	120.035	0.376	8.042
32	Mechanical power, kW					250	
33	Electrical power, kW					240	

Table 3. Energy and exergy balance equations for the cogeneration system components

N ^o	Component	Control volume	Energy and exergy balance equations
1	Biogas engine (BEa,b)		$\dot{m}_f LHV = \dot{m}_{cg,5a(b)}(h_{3a(b)} - h_{4a(b)}) + \dot{W}_{BEa(b)} +$ $+ \dot{m}_{ant,PC,14a(b)}(h_{14a(b)} - h_{15a(b)}) + \dot{Q}_{loss, BEa(b)} +$ $+ \dot{m}_{oil,35a(b)}(h_{35a(b)} - h_{36a(b)})$ $\dot{m}_{oil,35a(b)}(\varepsilon_{35a(b)} - \varepsilon_{36a(b)}) - \dot{W}_{BEa(b)} + \dot{m}_{af,4a(b)}(\varepsilon_{4a(b)} - \varepsilon_{5a(b)})$ $\left(1 - \frac{T_0}{T_{b, BEa,b}}\right) \dot{Q}_{loss, BEa(b)} + \dot{m}_{antPC,14a(b)}(\varepsilon_{14a(b)} - \varepsilon_{15a(b)}) = \dot{E}x_{D, BEa(b)}$
2	Mixer (M)		$\dot{m}_{a,0}h_0 + \dot{m}_{f,1}h_1 = \dot{m}_{af,2}h_2$ $(\dot{m}_{a,0}\varepsilon_0 + \dot{m}_{f,1}\varepsilon_1) - \dot{m}_{af,2}\varepsilon_2 = \dot{E}x_{D,M}$
3	Oil tank (OT)		$\dot{m}_{oil}(h_{37} - h_{35}) = \dot{Q}_{loss, OT}$ $\dot{m}_{oil,37}(\varepsilon_{37} - \varepsilon_{25}) + \left(1 - \frac{T_0}{T_{b, OT}}\right) \cdot \dot{Q}_{loss, OT} = \dot{E}x_{D, OT}$
4	Turbocharger (TCa,b)		$\dot{m}_{af,2a(b)}(h_{3a(b)} - h_{2a(b)}) = \dot{W}_{CMa(b)}$ $\dot{m}_{cg,6a(b)}(h_{5a(b)} - h_{6a(b)}) = \dot{W}_{TBa(b)}$ $\dot{m}_{af,2a(b)}\varepsilon_{2a(b)} - \dot{m}_{af,3a(b)}\varepsilon_{3a(b)} - \dot{W}_{Ma,(b)} = \dot{E}x_{D, CMa(b)}$ $\dot{m}_{cg,5a(b)}\varepsilon_{5a(b)} - \dot{m}_{cg,6a(b)}\varepsilon_{6a(b)} - \dot{W}_{TBa(b)} = \dot{E}x_{D, TBa(b)}$
5	Technological circuit cooler (TCC)		$\dot{m}_{ant,TC,13}(h_{13} - h_{19}) = \dot{Q}_{loss, TCC}$ $\dot{m}_{antTC,13}\varepsilon_{13} - \dot{m}_{antTC,9}\varepsilon_9 + \left(1 - \frac{T_0}{T_{b, TCC}}\right) \cdot \dot{Q}_{loss, TCC} = \dot{E}x_{D, TCC}$
6	Technological circuit water pump (WP1a,b)		$\dot{W}_{WP1a(b)} + \dot{m}_{ant,10a,b}(h_{11a(b)} - h_{10a(b)}) = 0$ $\dot{m}_{antTC,10a(b)}(\varepsilon_{10a(b)} - \varepsilon_{11a(b)}) - \dot{W}_{WP1a(b)} = \dot{E}x_{D, WP1}$
7	Charge cooler (CCa,b)		$\dot{m}_{af,3a(b)}(h_{3a(b)} - h_{4a(b)}) - \dot{m}_{ant,TC,11a(b)}(h_{12a(b)} - h_{11a(b)}) = \dot{Q}_{loss, CC}$ $(\dot{m}_{af,3a(b)}\varepsilon_{3a(b)} + \dot{m}_{ant,TC,11a(b)}\varepsilon_{11a(b)}) + \left(1 - \frac{T_0}{T_{b, TCC}}\right) \dot{Q}_{loss, TCC} -$ $-(\dot{m}_{af,4a(b)}\varepsilon_{4a(b)} + \dot{m}_{ant,TC,12a(b)}\varepsilon_{12a(b)}) = \dot{E}x_{D, TCC}$
8	Heat exchanger (HEX)		$\dot{m}_{w,SC,18}(h_{18} - h_{19}) + \dot{m}_{cg,7}(h_7 - h_8) = \dot{Q}_{loss, HEX}$ $(\dot{m}_{w,SC,18}\varepsilon_{18} + \dot{m}_{cg,7}\varepsilon_7) - (\dot{m}_{cg,8}\varepsilon_8 + \dot{m}_{w,SC,19}\varepsilon_{19}) +$ $+ \left(1 - \frac{T_0}{T_{b, HEX}}\right) \dot{Q}_{loss, HEX} = \dot{E}x_{D, HEX}$

Table 3. Energy and exergy balance equations for the cogeneration system components (cont.)

Nº	Component	Control volume	Energy and exergy balance equations
9	Secondary circuit water pump (WP2)		$\dot{W}_{WP2} - \dot{m}_{w,SC,29}(h_{31} - h_{30}) = 0$ $\dot{m}_{w,SC,30}\epsilon_{30} - \dot{m}_{w,SC,31}\epsilon_{31} - \dot{W}_{WP2} = \dot{E}x_{D,WP2}$
10	Plate heat exchanger from secondary circuit (PHEX (PC/SC))		$\dot{m}_{ant,PC}h_{16} + \dot{m}_{w,SC}h_{31} =$ $= \dot{m}_{ant,PC}h_{17} + \dot{m}_{w,SC}h_{18} + \dot{Q}_{loss,PHEX(PC/SC)}$ $(\dot{m}_{ant,PC,16}\epsilon_{16} + \dot{m}_{w,SC,17}\epsilon_{17}) - (\dot{m}_{ant,PC,17}\epsilon_{17} + \dot{m}_{w,SC,18}\epsilon_{18}) +$ $+ \left(1 - \frac{T_0}{T_{b,PHEX(PC/SC)}}\right) \cdot \dot{Q}_{loss,PHEX(PC/SC)} = \dot{E}x_{D,PHEX(PC/SC)}$
11	Hydraulic separator (HR)		$\dot{m}_{w,20}h_{20} + \dot{m}_{w,28}h_{28} = \dot{m}_{w,21}h_{21} + \dot{m}_{w,29}h_{29}$ $\dot{m}_{w,20}(\epsilon_{20} - \epsilon_{29}) + \dot{m}_{w,21}(\epsilon_{28} - \epsilon_{21}) = \dot{E}x_{D,HS}$
12	Cooling circuit water pump (WP3)		$\dot{W}_{WP3} - \dot{m}_{ant,25}(h_{25} - h_{24}) = 0$ $\dot{m}_{ant,Cn,24}\epsilon_{24} - \dot{m}_{ant,Cn,25}\epsilon_{24}\epsilon_{25} - \dot{W}_{WP3} = \dot{E}x_{D,WP3}$
13	Air – cooled radiator (ACR)		$\dot{m}_{ant,CC,25}(h_{25} - h_{26}) = \dot{Q}_{ACR}$ $\dot{m}_{ant,Cn,25}\epsilon_{25} - \dot{m}_{ant,Cn,26}\epsilon_{26} + \left(1 - \frac{T_0}{T_{b,ACR}}\right) \dot{Q}_{loss,ACR} = \dot{E}x_{D,ACR}$
14	Plate heat exchanger from cooling circuit (PHEX (CC))		$\dot{m}_{w,CC}(h_{22} - h_{28}) + \dot{m}_{ant,27}(h_{27} - h_{23}) = \dot{Q}_{loss,PHEX(CC)}$ $(\dot{m}_{ant,CC,27}\epsilon_{27} + \dot{m}_{w,CC,22}\epsilon_{22}) - (\dot{m}_{ant,CC,23}\epsilon_{23} + \dot{m}_{w,CC,28}\epsilon_{28}) +$ $+ \left(1 - \frac{T_0}{T_{b,PHEX(CC)}}\right) \cdot \dot{Q}_{PHEX(CC)} = \dot{E}x_{D,PHEX(CC)}$
15	Generator (G)		$\dot{W}_{32} = \dot{W}_{33} + \dot{W}_{loss,G}$ $\dot{E}x_{32} - \dot{E}x_{33} = \dot{E}x_{D,G}$

Thermodynamic performance assessment parameters of the cogeneration system with a biogas engines and its components

The energy efficiency of the cogeneration system can be defined as ratio of the system products – electrical and heat energy to the total fuel energy input. Thus, the cogeneration system can be assessment according to the first law of thermodynamics. The energy efficiency is obtained from (Gohstain and Werhivker, 1985; EDUCOGEN, 2001):

$$\eta_{cogen} = \frac{\dot{W}_{el} + \dot{E}_Q}{\dot{E}_f} \tag{4}$$

The exergy efficiency of the system can be defined as similar way:

$$\eta_{EX,cogen} = \frac{\dot{W}_{el} + \dot{E}x_Q}{\dot{E}x_f} \tag{5}$$

The exergy efficiencies of the *k*th system component are calculated by the equation (EDUCOGEN, 2001):

$$\eta_{EX,k} = \frac{\dot{E}x_{p,k}}{\dot{E}x_{f,k}} \tag{6}$$

Furthermore, in this paper the following thermodynamic performance assessment parameters are used in evaluating the thermodynamic performance of the cogeneration system:

- Power to heat ratio (PHR) (EDUCOGEN, 2001; Balli and Aras, 2010a):

$$PHR = \frac{\dot{W}_{el}}{\dot{E}_Q} \tag{7}$$

- Fuel energy saving ratio (FESR) (EDUCOGEN, 2001; Balli and Aras, 2010a):

$$\eta_{FESR} = 1 - \frac{1 + PHR}{\eta_{cogen} \cdot \left(\frac{PHR}{\eta_W} + \frac{1}{\eta_Q} \right)} \tag{8}$$

where, the subscripts *W* and *Q* denote the energy efficiencies at separate production of electricity and heat, respectively.

- Energy efficiency used under the Public Utilities Regulatory Policy Act (PURPA) (U.S. EPA OAR, 2005; Balli and Aras, 2010a):

The PURPA efficiency can be considered as a minimum efficiency standard for cogeneration units according to the National Energy Act of USA. In order to calculate its numerical value, we must be taken an account only half of the heat energy of the product:

$$\eta_{PURPA} = \frac{\dot{W}_{el} + 0.5\dot{E}_Q}{\dot{E}_f} \tag{9}$$

In many cases, however, exergy destruction due to heat transfer from a hot stream to a cold stream in a system is greater than 50%.

In present study, the thermodynamic performance assessment parameters of the cogeneration system, described above, are calculated based on the exergy terms, as noted by (Abusoglu and Kanoglu, 2009a). The results are discussed in

the next paragraph. The PURPA efficiency is not determined on exergy base, because such a calculation does not make a thermodynamic sense.

Moreover, in current investigation the several thermodynamic performance assessment parameters such as exergy destruction ratio, relative irreversibility, productivity lack and exergetic improvement potential are determined in order to assessment the thermodynamic efficiency of system components. These parameters are given below.

The exergy destruction ratio is defined as the ratio of the exergy destruction within *k*th system component to the total fuel exergy input (Tsatsaronis, 2002; Balli and Aras, 2010a):

$$y_D = \frac{\dot{E}x_{D,k}}{\dot{E}x_{F,tot}} \tag{10}$$

The relative exergy consumption ratio is expressed as the ratio of the exergy destruction within *k*th system component to the total exergy destruction of the system. Thus, it can be established the system component with the highest irreversibility (Tsatsaronis, 2002; Balli and Aras, 2010a):

$$\beta_k = \frac{\dot{E}x_{D,k}}{\dot{E}x_{D,cogen}} \tag{11}$$

Another parameter determined in this paper is the productivity lack ratio, permitting to be diagnosed the thermodynamic behavior of the system components. It can be calculated from the ratio of the exergy consumption of the *k*th component to the exergy of useful products:

$$\chi_k = \frac{\dot{E}x_{D,k}}{\dot{E}x_{UP,k}} \tag{12}$$

The author of (Van Gool, 1997) argues that the maximum improvement of the exergy efficiency of the cogeneration system *k*th component can be expected when exergy losses or irreversibilities are minimized. As a result of this opinion is introduced exergetic improvement potential (Van Gool, 1997; Balli and Aras, 2010a):

$$EIP_{EX,k} = (1 - \eta_{EX,k}) \cdot \dot{E}x_{D,k} \tag{13}$$

RESULTS AND DISCUSSION

The results from calculations of the system thermodynamic efficiency (table 4) demonstrate the value for the energy and exergy efficiency of 53.347% and 34.636%, respectively. The exergy efficiency results obtained in this paper are compared with those of other studies (Abusoglu and Kanoglu, 2009b; Yildirim U. and Gungor A., 2012), where the cogeneration systems are driven by compression ignition (CI) internal combustion engine (ICE) burned heavy fuel oil. The data listed in those papers designate that about 40% of exergy entering the plants is converted to the exergy of the product in these CHP systems. In another study (Balli and Aras, 2010b) investigating a trigeneration system with a gas-diesel engine, the exergy efficiency is calculated as 36.13%. Therefore, the cogeneration system operates with efficiency slightly variant than others (i.e. the agreement is good), due to the differences in the engine

cycle, the fuel type, the rate of production electrical energy et al.

Table 4. Energetic and exergetic performance assessment parameters of the overall cogeneration system

Energetic performance assessment parameters			Exergetic performance assessment parameters		
Data	Unit	Value	Data	Unit	Value
η_{cogen}	%	53.347	$\eta_{EX,cogen}$	%	34.636
η_{FESR}	%	50.00	$\eta_{EX,FESR}$	%	50.00
PHR	-	1.714	PHR_{EX}	-	11.735
η_{PURPA}	%	43.836			

A comparison of the exergy efficiency value with those of the other configurations cogeneration systems reveals the following: the second law efficiency of gas-turbine based cogeneration systems is with the range 50%-52% (Huang F., 1990; Bilgen, E., 2000; Doseva, N., Chakyrova, D., 2012) and those results are higher than the exergy efficiency of the analyzed system. The second law efficiency, however, increased significantly to 62%, when a gas-turbine based cogeneration systems is equipped with solid oxide fuel cells (SOFC) (Colpan, C., Dincer, I. et al., 2008). Based on data stated above, it can be conclude that to the objective assessment of specific technological option for configuring a CHP plant, it is necessary the system to be thermoeconomic analyzed.

Another parameter determined in this study is power to heat ratio (PHR). As Table 4 shows, there is a significant difference between the value of the PHR determined on energy base and that expressed as a ratio of exergy of the produced work and exergy of the produced heat. These results consolidate the abilities of exergetic performance parameters, namely: they evaluate qualitatively and quantitatively the energy conversion from one form to another.

If a cogeneration system has a fuel energy saving ratio higher than zero, the CHP plant can be defined as a rational choice from the point of view of energy savings (EDUCOGEN, 2001). The difference in the data obtained from calculation of η_{FESR} and $\eta_{EX,FESR}$ is negligible and the values are determined to be 50%. In other words, the cogeneration system driven by biogas engines reduces the total fuel energy (exergy) consumption by 50.0% and it can be concluded, that the system is rational choice from the point of view of energy (exergy) savings.

In 1978 the United States Act of Congress was enacted the Public Utility Regulatory Policies Act (PURPA) – a part of the National Energy Act. A key purpose of PURPA was to encourage the development of cogeneration and renewable energy facilities in the United States. According to this act, if a CHP plant has $\eta_{PURPA} > 42.5\%$, it can be assessed as high efficiency system (U.S. EPA OAR, 2005). Therefore, based on

the presented data in Table 4, it can be conducted that the investigated cogeneration system is highly efficient one.

The results obtained from calculations of the parameters introduced by equations (10) - (13) unambiguously show the following: referring to the numerical data in table 5, it can be seen that the biogas engines (BEa,b), the heat exchangers (HEX, PHEX CC) and the mixer (M) are the components having the greatest influence on the system thermodynamic efficiency. The biogas engines have values for the exergy destruction ratio, relative irreversibility and productivity lack amounting to 6.449%, 12.47% and 13.356%, respectively. Furthermore, the conducted detailed exergy analysis on component level indicates that improvement efforts should be directed to the biogas engines, having an exergetic improvement potential value 26.9621 kW. Therefore, the biogas engine (BEa, BEb) are the most critical system units. The findings of the current study are consistent with those of Abusoglu A. and Kanoglu M. (2009b), Balli O. and Aras H. (2010b), Yildirim U. and Gungor A. (2012), who indicated that the engine is the unit with the highest value of the exergy destruction ratio. In addition, the results obtained in the listed above studies lead to the following conclusion: if instead of biogas engine, we use any alternative engine, it will not achieve significant improvement. It could be done, if we minimizing the irreversibility within entire system. Then, in order to achieve significant improve of the exergy efficiency of the system, we should be used an alternative cogeneration system configuration, where instead of combustion process, we have process characterized in a lower irreversibility. From an engineering point of view, such a measure could be carried out by using solid oxide fuel cell (SOFC) based cogeneration system, and the results presented in (Colpan, C., Dincer, I. et al., 2008) confirmed this statement.

Table 5. Exergetic performance assessment parameters of the cogeneration system components

Component	γ_D , %	β_k , %	χ_k , %	$\dot{E}IP_{EX,k}$, kW
BEa(b)	6.449	12.47	13.356	26.962
M	1.115	2.156	2.309	0.241
CMa(b)	0.468	0.906	0.970	0.5797
TBa(b)	0.078	0.15	0.106	0.0523
TCC	0.144	0.278	0.297	1.724
WP1a(b)	0.021	0.041	0.044	0.301
CCa(b)	0.197	0.381	0.408	2.772
HEX	3.451	6.673	7.147	33.362
WP2	0.021	0.041	0.0435	0.226
PHEX PS/SC	0.158	0.305	0.326	0.773
G	0.665	1.286	1.377	0.4
PHEX CC	1.157	2.237	2.396	11.605
HS	0.056	0.109	0.117	0.0106
WP3	0.037	0.071	0.0763	0.517
ACR	0.118	0.229	0.2452	1.003
OT	0.221	0.428	0.458	1.9374

From the data in figure 2, it is clear that the units with the lower exergy efficiency are the water pumps (WP3 and WP1), followed by the heat exchangers (CC and TCC). The reason for these values is the large differences in potentials (pressure and temperature) and as a result of this high level irreversibility.

By contrast the water pumps and heat exchangers, the system components with the highest exergy efficiency, as can see from figure 2, are hydraulic separator (HS), mixer (M) and generator (G) – 98.75%, 98.56% and 96%, respectively.

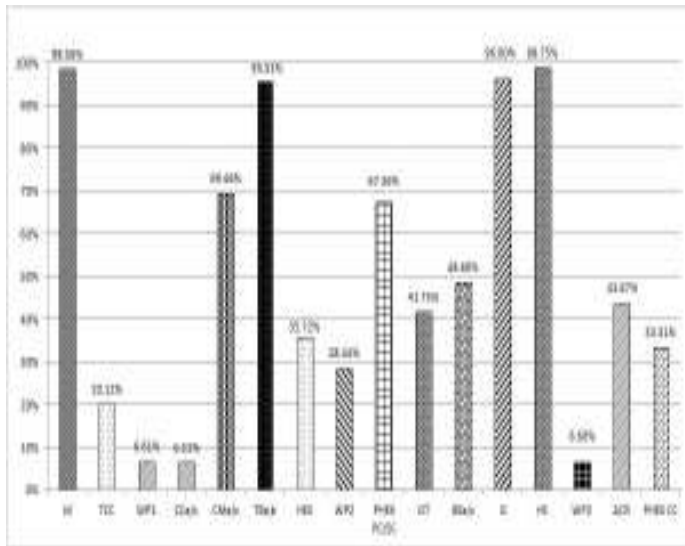

Fig. 2. Exergy efficiency of cogeneration system component

The exergy efficiency of the biogas engines (BEa, BEb) is determined to be 48.6% and if we increase this value, the overall system exergy efficiency will also become higher. As noted by Sayin, C et al., (2006) and Sekmen et al. (2011), the greatest influence over the exergy efficiency of spark-ignition engines have operating and design parameters such as load, speed, compression ratio and etc. Therefore, in order to improve exergy efficiency of the cogeneration system, optimization of those engine variables should be performed. It would be interesting to consider the influence of dead state temperature over exergy efficiency of the overall cogeneration system, since it is known from results presented by Caliskan, Tat et al. (2009) that the second law efficiency of internal combustion engine raises with increasing of dead state temperature.

CONCLUSIONS

In this paper has presented the methodology for assessment the thermodynamic efficiency of ICE based cogeneration systems for use with biogas from wastewater treatment plants. The methodology includes: (i) formulating of the balance energy and exergy balance equations of the cogeneration system components; (ii) determining of the following energy and exergy performance assessment parameters: system efficiency, fuel energy / exergy saving ratio, power to heat ratio,

the PURPA efficiency and (iii) detailed assessment on component level.

The findings from thermodynamic performance evaluation (see Table 4) of the cogeneration system driven by biogas engines indicate that the operation at 75% of total electrical output is efficiency one from thermodynamic point of view. Moreover, this study has shown that the biogas engines are the most destructive units in the plant. Small improvements in engines operation parameters can provide better increase in system thermodynamic performance compared to large improvements in other components such as turbomachinery and hydraulic separator. It is important to note that any decision to improve exergy efficiency of the cogeneration system must be taken after detailed considering the effect of the optimized parameters on the economic performance of the system (for instance, the cost of the final products). Such a problem could be solved by applying of the thermoeconomic method for analysis and optimization of industrial systems.

The results of this research support the idea that the legal regulated minimal thermodynamic efficiency of the CHP system must be replaced with parameters relating to the second law of thermodynamics.

Although the paper provides an essential answers about what is thermodynamic behavior of cogeneration system driven by biogas engines and its components, several questions remain unanswered at present. In this paper, an analysis of the thermodynamic performance parameters at different system outputs is not conducted. This would be a fruitful area for further work. Moreover, the authors intend to refine the thermodynamic model of cogeneration installation by examining the effect of the outlet streams temperature on the exergy destruction ratio of the biogas engines, heat exchanger and turbochargers, as well as the effect of the inlet temperature of the fuel-air mixture on the exergy destruction ratio of biogas engines. It would be helpful to know what part of the exergy destruction within system components can be avoided by technological improvement. Moreover, the assessment of economic efficiency of the system may be of interest to all operators, designers and researchers of CHP systems for use with biogas from wastewater treatment plants. A future studies with more focus on these topics is therefore suggested.

In conclusion, the presented methodology in this paper can be useful in the analysis, design and optimization of ICE based cogeneration systems for use with biogas from wastewater treatment plants.

In addition, the authors regarded the obtained results as input data of the following thermoeconomic optimization of cogeneration system installed in Varna Wastewater Treatment Plant.

NOMENCLATURE

- Roman letters*
- e specific energy (kJ/kg)
 - \dot{E} energy rate (kW)
 - \dot{E}_x exergy rate (kW)

h	specific enthalpy (kJ/kg)
LHV	lower heating value of fuel (MJ/kg)
\dot{m}	mass flow rate (kg/s)
\dot{Q}	heat rate (kW)
\dot{Q}_{loss}	heat loss rate (kW)
p	pressure (Pa)
s	specific entropy (kJ/kgK)
T	temperature (K)
T_b	temperature of the boundary, where the heat transfer is occurred (K)
\dot{W}	work (kW)

Greek letters

ε	specific exergy (kJ/kg)
η	energy efficiency (%)
η_{ex}	exergy efficiency (%)

Subscripts

a	air
af	air – fuel mixture
ant	antifreeze
cg	combustion gases
$cogen$	cogeneration system
D	exergy destruction
ex	exergy
f	fuel
in	inlet flow
oil	lube oil
out	outlet flow
w	water

REFERENCES

- Abusoglu A., Kanoglu M., 2009a. Exergetic and Thermoeconomic Analysis of Diesel Engine Powered Cogeneration: Part I – Formulations, *Journal of Applied Thermal Engineering*, 29(2-3), p. 234-241.
- Abusoglu A., Kanoglu M., 2009b. Exergetic and thermoeconomic analyses of diesel engine powered cogeneration: Part 2 – Application. *Journal of Applied Thermal Engineering*, 29(2-3), p. 242-249.
- Badami, M., Mura, M., 2010. Exergetic analysis of an innovative small scale combined cycle cogeneration system. *Journal of Energy*, 35 (6), p.2535-2543.
- Balli O., Aras H., 2010a. Thermodynamic and Thermoeconomic Analyses of Trigenation (TRIGEN) System with a Gas-Diesel Engine: Part I – Methodology, *Journal of Energy Conversion and Management*, 51, p.2252-2259.
- Balli O., Aras H., 2010b. Thermodynamic and thermoeconomic analyses of a trigeneration (TRIGEN) system with a gas-diesel engine: Part II – An Application. *Journal of Energy Conversion and Management*, 51(11), p. 2260-2271.
- Bejan A., Tsatsaronis G., 1996. *Thermal Design and Optimization*. New York, USA: John Willey & Sons Ltd.
- Bilgen, E., 2000. Exergetic and engineering analyses of gas turbine based cogeneration systems. *Journal of Energy*, 25, p. 1215-1229.
- Bonnet, S., Alaphillippe, M. et al., 2005. Energy, exergy and cost analysis of a micro-cogeneration system based on an Ericsson engine. *International Journal of Thermal Science*, 44 (12), p. 1161-1168.
- Caliskan H., Tat M.E., Hepbasli A., and Van Gerpen J...H., 2010. Exergy analysis of engines fuelled with biodiesel from high oleic soybeans based on experimental values, *International Journal of Exergy*, 7, p.20-36.
- China Energy Conservation Investment Corporation, Energy Resources International, Inc., 2001. Market assessment of cogeneration in China. [pdf] Available at: https://www.appa.org/files/PDFs/EDUCOGEN_Cogen_Guide.pdf [Accessed 11 October 2014].
- Colpan, C., Dincer, I., Hamdullahpur, F., 2008. Exergy analysis of a SOFC based cogeneration system for buildings. Transactions of ASHRAE, Winter Meeting, New York City, January 19-23.
- EDUCOGEN, 2001. *The European Education Tool on Cogeneration System*. [pdf] Available at: https://www.appa.org/files/PDFs/EDUCOGEN_Cogen_Guide.pdf [Accessed 22 April 2012].
- Fagbenle, R., Oguaka, A. et al., 2007. A thermodynamic analysis of a biogas-fired integrated gasification steam injected gas turbine (BIG/STIG) plant. *Journal of Applied Thermal Engineering*, 27 (13), p.2220–2225.
- Huang F., 1990. Performance evaluation of selected combustion gas turbine cogeneration systems based on first and second-law analysis. *Journal of Engineering for Gas Turbines and Power*, 112, p.117–121.
- Kamboj, S., Karimi, M., 2013. The effects of compression ratios and fuels on the energetic, exergetic and ecological efficiency of an air standard Otto cycle. *International Journal of Energy Science (IJES)*, 3 (5), p. 320-332.
- Kyritsis D., Rakopoulos C., 2001a. Parametric study of the availability balance in an internal combustion engine cylinder. SAE paper no. 2001-01-1263. Warrendale, PA: Society of Automotive Engineers Inc.
- Moran M., Shapiro H., 2006. *Fundamentals of Engineering Thermodynamics*. 5th ed. England: John Wiley & Sons Ltd.
- More, P., Aijaz, A., 2014. Thermal analysis of energy and exergy of back pressure steam turbine in sugar cogeneration plant. *International Journal of Emerging Technology and Advanced Engineering*, 4 (1), p.674-682.
- Ozkan, D., Kiziler, O. et al., 2012. Exergy Analysis of a Cogeneration Plant. *World Academy of Science, Engineering & Technology*, 6 (1), p.647-651.
- Rakopoulos C., Kyritsis D., 2001b. Comparative second-law analysis of internal combustion engine operation for methane, methanol and dodecane fuels. *Journal of Energy*, 26, p. 705–722.

- Sayin, C., Hosoz, M. et al., 2006. Energy and exergy analysis of gasoline engine. *International Journal of Energy Research*, Published online in Wiley InterScience [pdf]. Available at: http://akademikpersonel.kocaeli.edu.tr/ikaslani/sci/ikaslani04.11.2011_11.43.47sci.pdf
[Accessed 05 October 2014]
- Sekmen P, and Yilbasi Z., 2011. Application of energy and exergy analyses to a CI engine using biodiesel fuel. *Journal of Mathematical and Computational Applications*, 16, p.797-808. U.S. EPA OAR, 2005. Technical Support Document for the Final Clean Air Interstate Rule: Cogeneration Unit Efficiency Calculations. EPA Docket Number: OAR-2003-0053 [pdf]. Available at: http://www.epa.gov/cleanairinterstaterule/pdfs/tsd_cogen.pdf
[Accessed 18 October 2014]
- Van Gool W., 1997. Energy policy: fairy tales and factualities. *Journal of Innovation and Technology*, p. 93-105.
- Yildirim U., Gungor A., 2012. An application of exergoeconomic analysis for CHP system. *International Journal of Electrical Power & Energy Systems*, 42(1), p.250-256.
- Гохштейн Д.П., Верхивкер Г.П., 1985. *Применение метода вычитания к анализу работы энергоустановок*. Киев, Вища школа. (Gohstain, D.P., Werhivker, G.P., 1985. Application of the thermodynamic analysis methods to energy conversion system, Kiev, Visha shkola)
- Досева Н., Чакърова Д., 2012. Оценка производительности на теоретична когенерационна инсталация. *Трети международен научен конгрес, 04-06 октомври, Варна, България*, 5, стр. 147-153. (Doseva, N., Chakurova, D., 2012. Performance evaluation of a theoretical cogeneration plant. *3rd International Scientific Conference, 04-06 October, Varna, Bulgaria*, 5, p.147-153)
- Тсатсаронис, Дж., 2002. Взаимодействие термодинамики и экономики для минимизации стоимости энергопреобразующей системы. Одесса: ООО „Студия „Негоциант“. (Tstatsaronis, G., 2002. Combination of Exergetic and Economic Analysis in Energy-Conversion Processes. Odessa, Studio Negotiant.